

ASSEMBLY INSTRUCTIONS

UARM

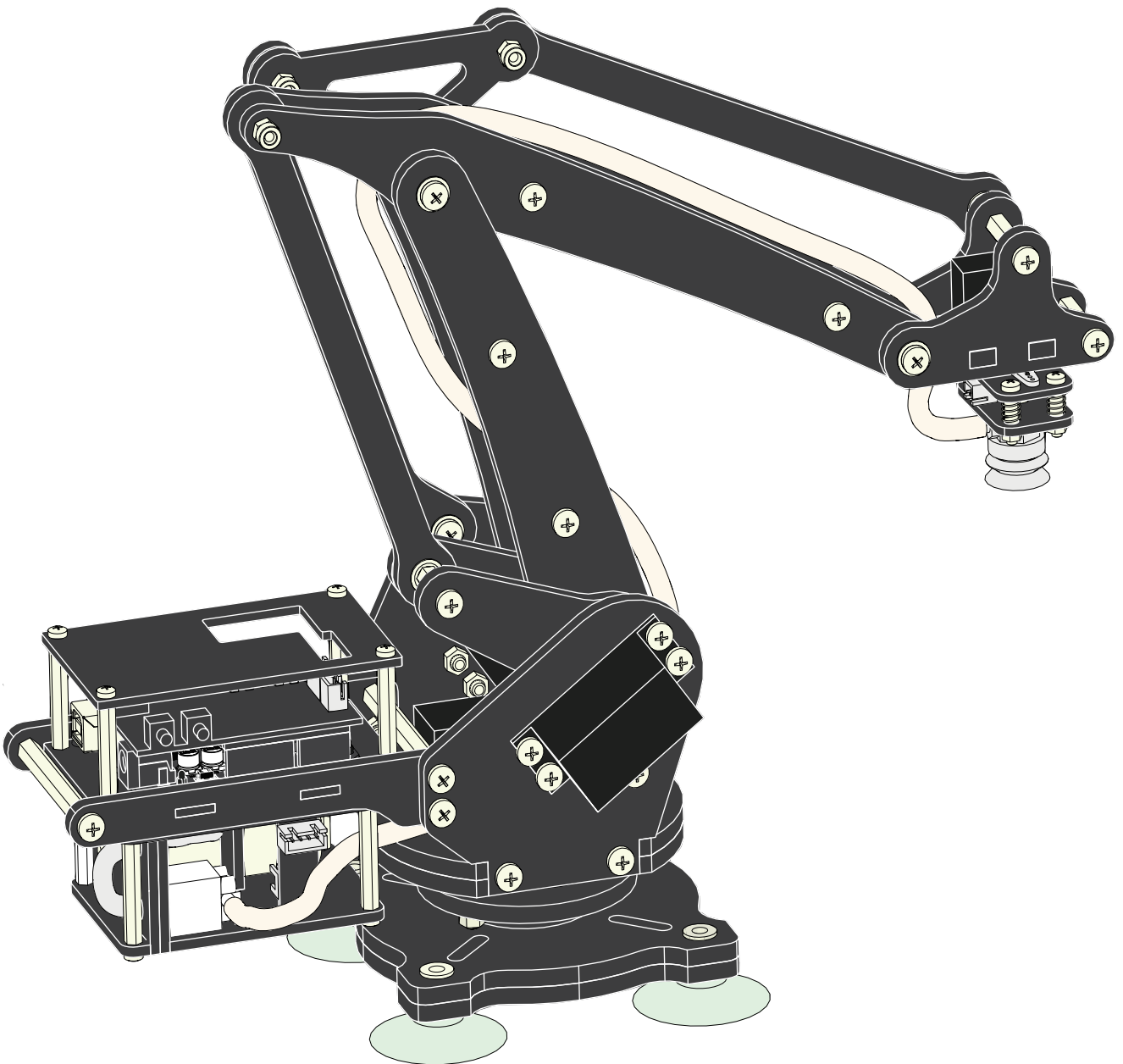

uArm Replaceable Kit Part List

Mechanical Parts			
Item number	Item name	Item description	Qty
1	Acrylic Parts	Acrylic Board	4

Components					
Item number	Item name	Item description	Qty		
1	For Basic uArm 1	Screw M4-8	16		
		Screw M4-16	11		
2	For Basic uArm 2	Screw M4-12	12		
		Screw M4-22	1		
3	For Basic uArm 3	Screw M4-14	4		
		Screw M4-25	8		
4	For Basic uArm 4	Screw M2-10	2		
		Tapping Screw M2-10	8		
		Tapping Screw M2-12	4		
5	For Basic uArm 5	Nut M2	2		
		Nut M4	24		
		Lock Nut M4	4		
6	For Basic uArm 6	Metal Spacer 4x10x1	5		
		Shaft Sleeve M4-7	1		
7	For Basic uArm 7	Brass Stand-offs M4-10	4		
		Brass Stand-offs M4-15	1		
		Brass Stand-offs M4-22	4		
		Brass Stand-offs M4-55	2		
		Brass Stand-offs M4-65	1		
		Aluminum Alloy Rod 8-45	1		
8	For Basic uArm 8	Thin-walled Bearing 61807	1		
		Flange Bearing MF84ZZ	12		
		Flange Shaft Sleeve	12		
9	For Basic uArm 9	Suction Cup 45-M5	4		
		Rivet M5-10	4		
10	For Basic uArm 10	Screw M4-28	3		
		Screw M2-10	2		
11	For Gripper	Screw M3-8	4		
		Screw M3-25	1		
		Screw M4-16	2		
		Nut M2	2		
		Nut M3	2		
		Lock Nut M4	2		
		Brass Stand-offs M3-8	2		
		Metal Spacer 4-10-1	2		
		Shaft Sleeve 2.5-3-4	1		
		Plastic Spacer 3-7-10	1		
		Plastic Spacer 4-7-5	2		
		12	For Suction Cup End-effector 1	Brass Stand-offs M3-30	4
				Brass Stand-offs M3-5#6	4
Screw M3-5	8				
Screw M3-16	4				
Nut M3	4				
Shaft Sleeve 3-4-10	4				
Spring	4				
13	For Suction Cup End-effector 2	Suction Cup DP-10	1		
		Suction Cup DP-20	1		
		Suction Cup Holder	1		
14	For Suction Cup End-effector 3	Nut M5	1		
		Dust Filter	3		
15	For Controller Board	Plastic Rivet 3080	4		
		Brass Stand-offs M3-30	4		
		Screw M3-8	8		

Electronic Parts			
Item number	Item name	Item description	Qty
1	Pump	Pump	1
2	Valve	Valve	1
3	Silicone Tubing	Silicone Tubing (650mm)	1
		Silicone Tubing (80mm)	1
4	Servo	U-Servo US-D150A	3
		U-Servo US-D009A	2
5	USB Cable	USB Cable (1.8m)	1
6	Power Supply	Power Supply	1
		Power Supply Cable	1
7	Uduino	Arduino Uno	1
8	uArm Shield	uArm Shield	1
9	Pump Kit Board	Pump and Valve Driver	1
		4Pin Cable (150mm)	
10	Limit Switch	Limit Switch	1
		2Pin Cable (550mm)	1

Tools			
Item number	Item name	Item description	Qty
1	Screw Driver	Screw Driver	1
2	Cone Wrench	Cone Wrench	1

Download uArm Assembly Instructions and Software here:
<http://ufactory.cc/downloads.html>

Acrylic Parts

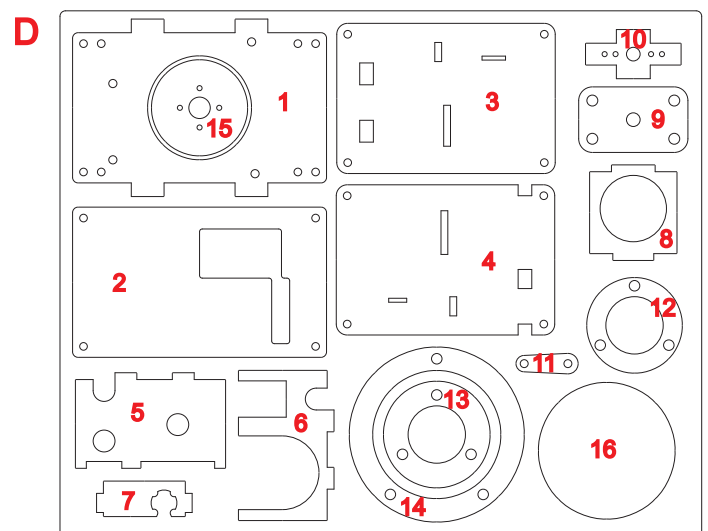
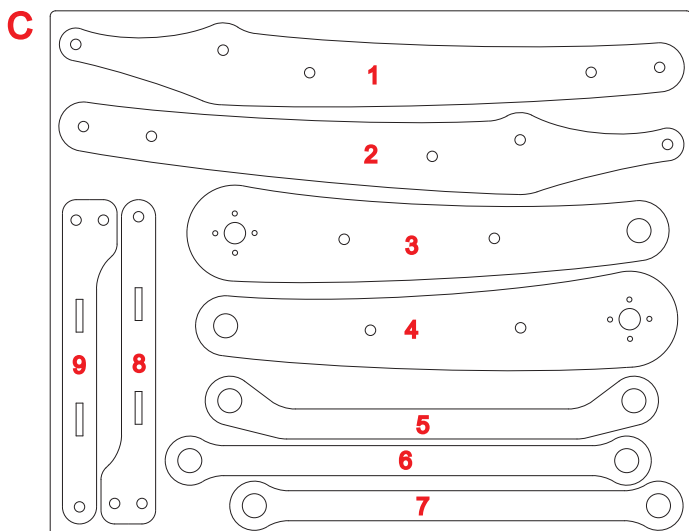
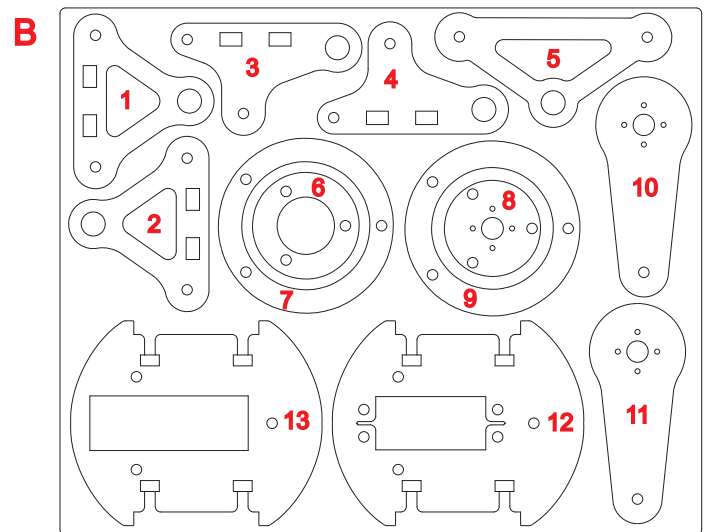
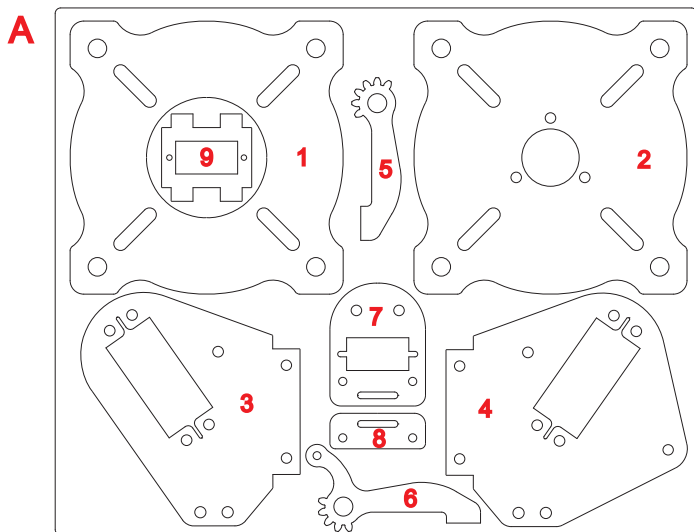

uArm assembly

1.

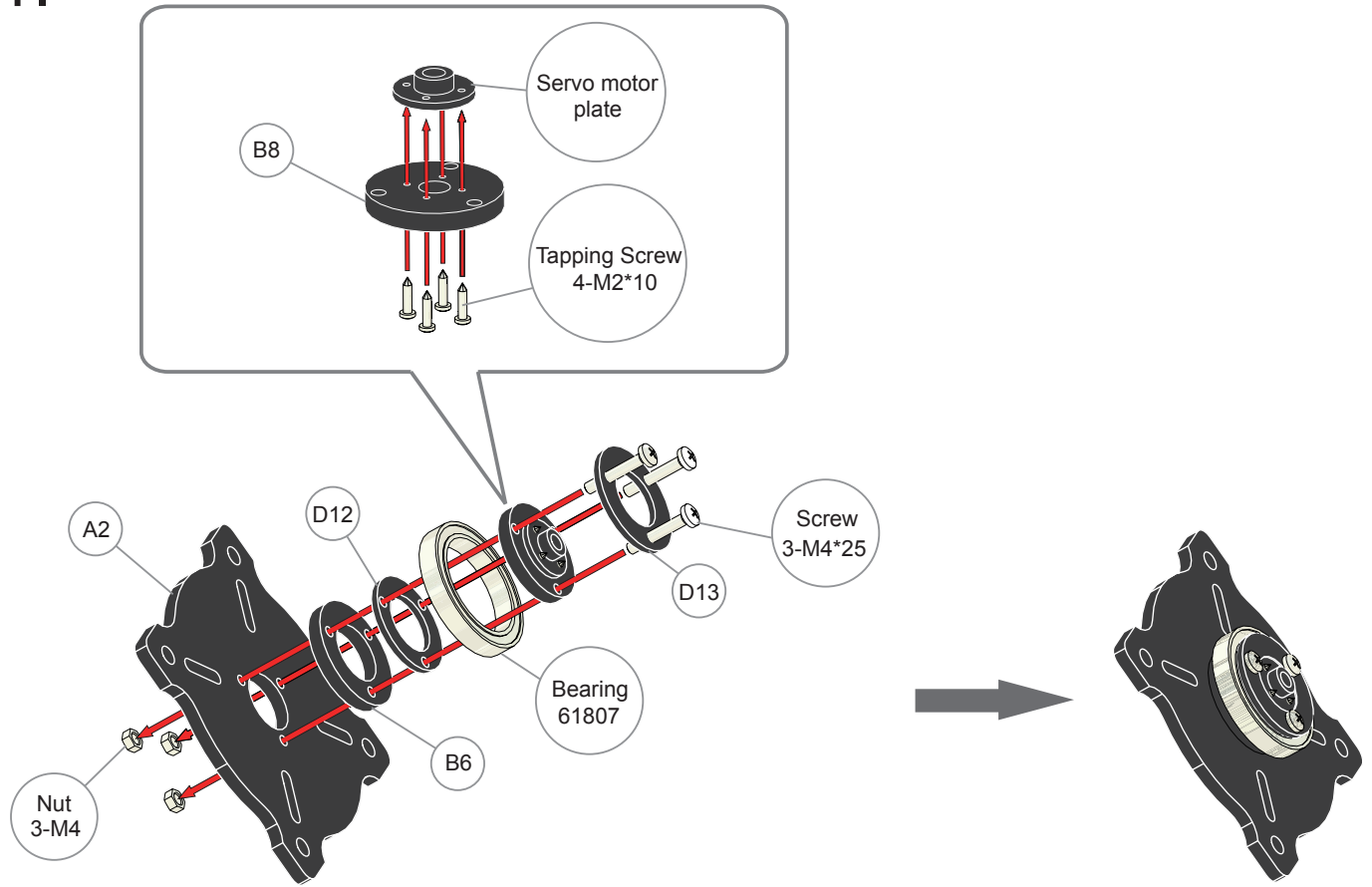

2.

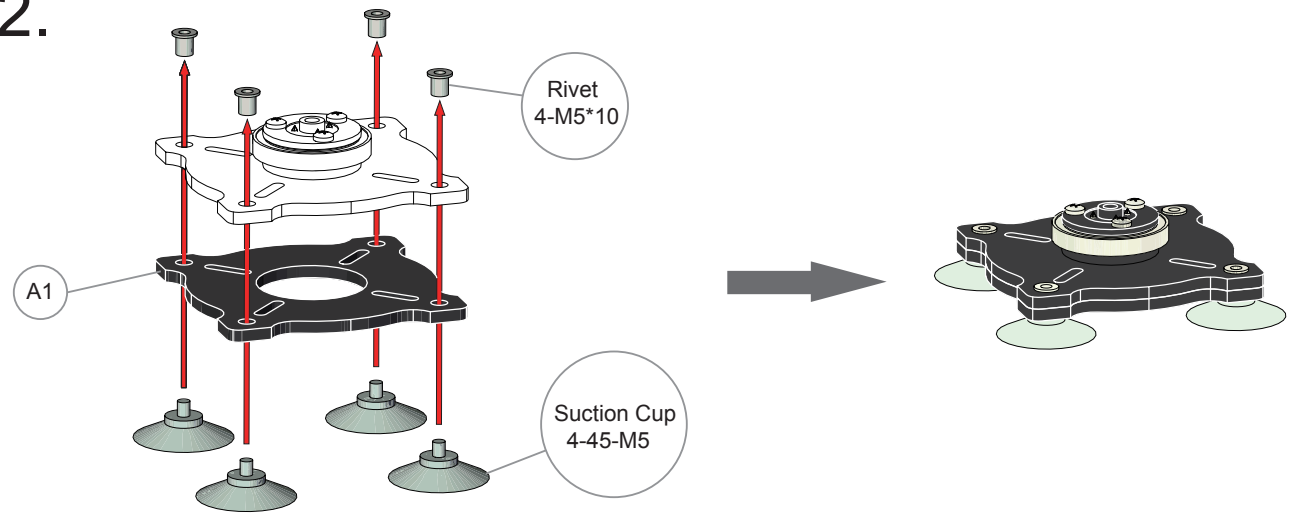

3.

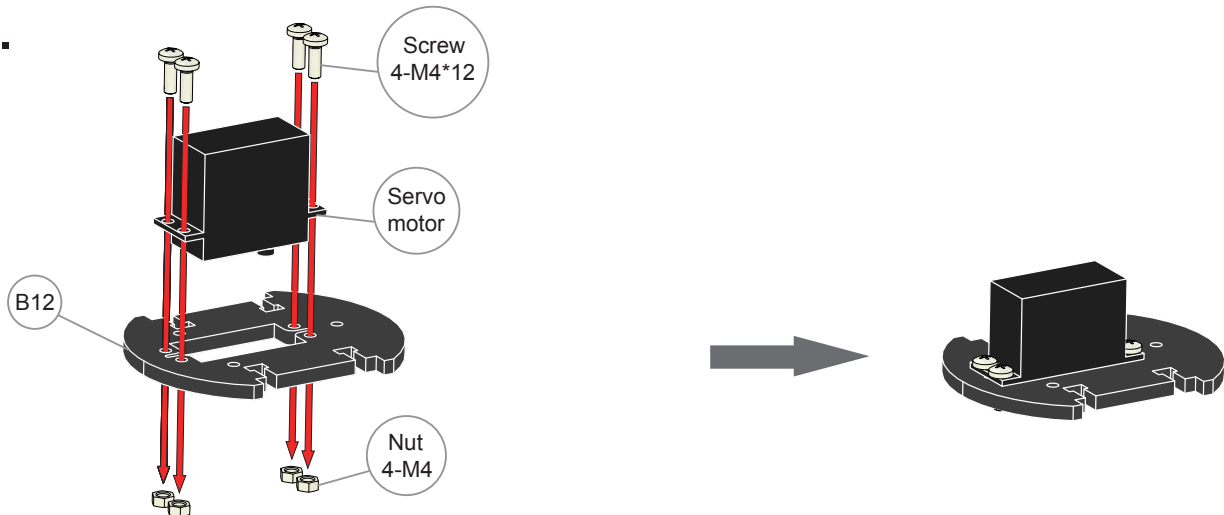

4.

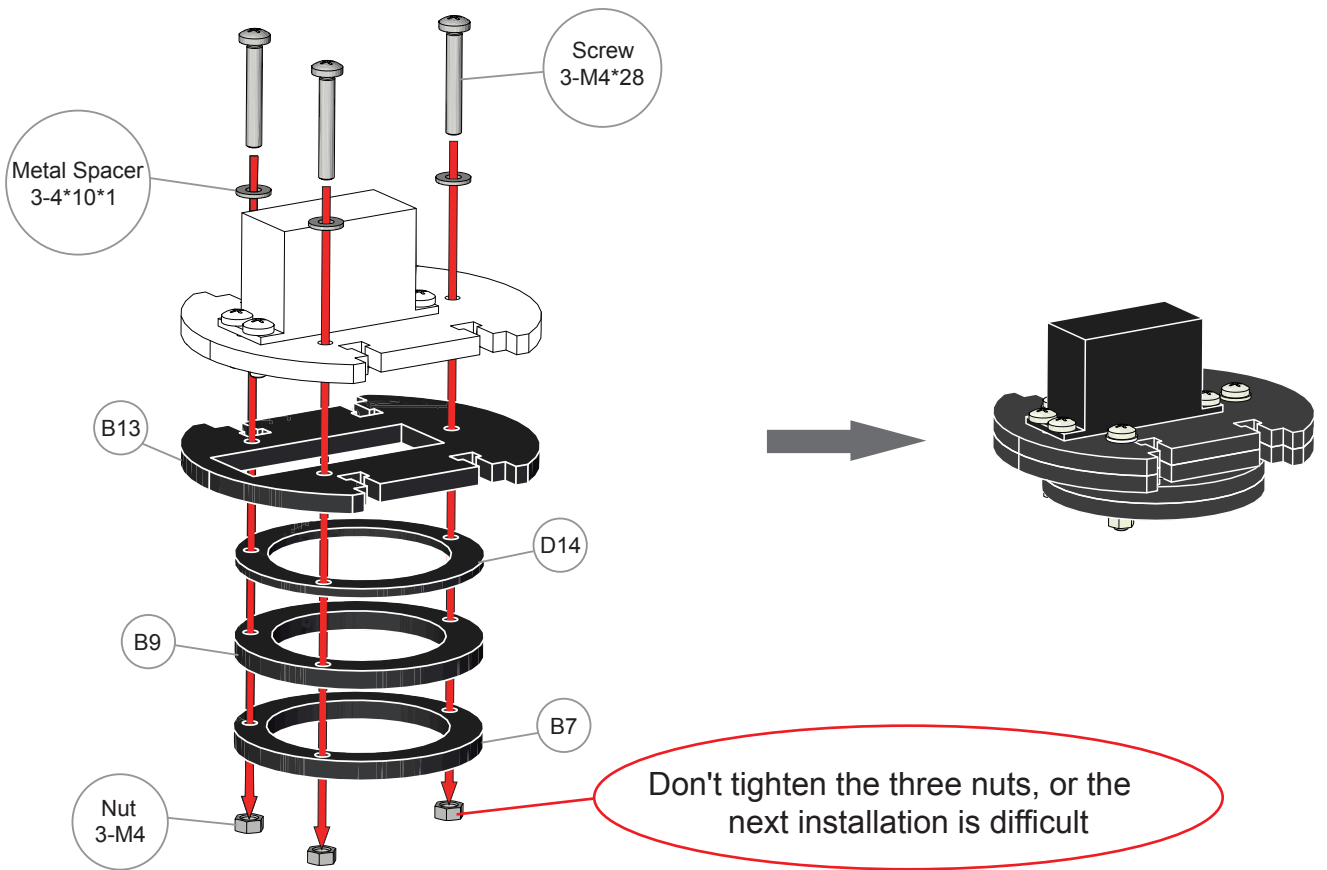

5.

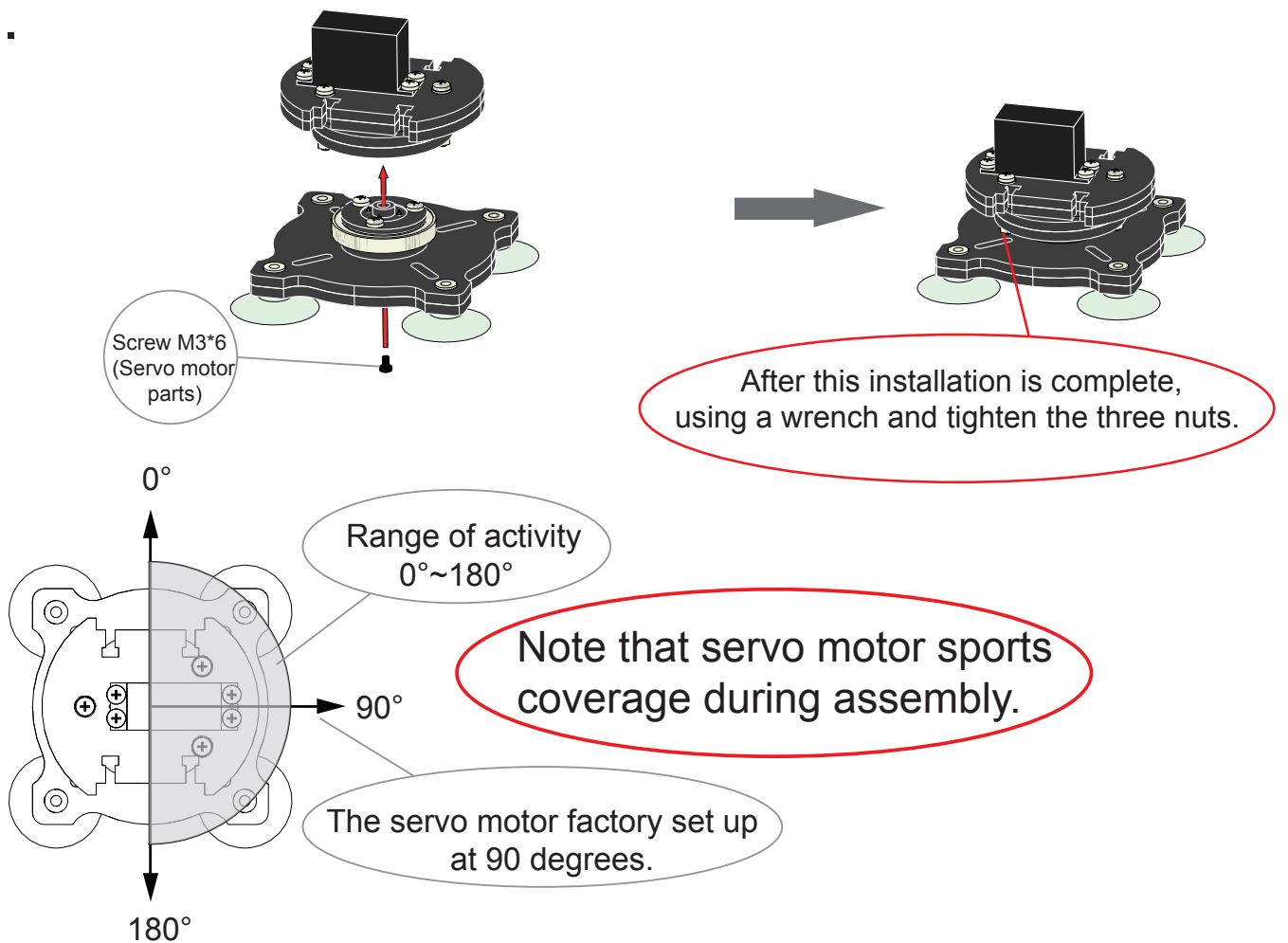

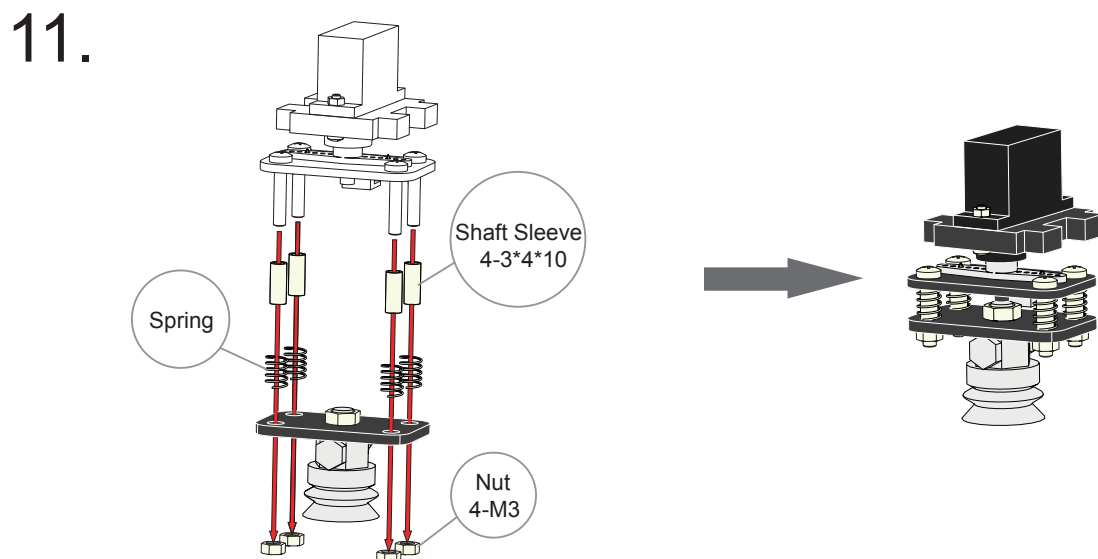
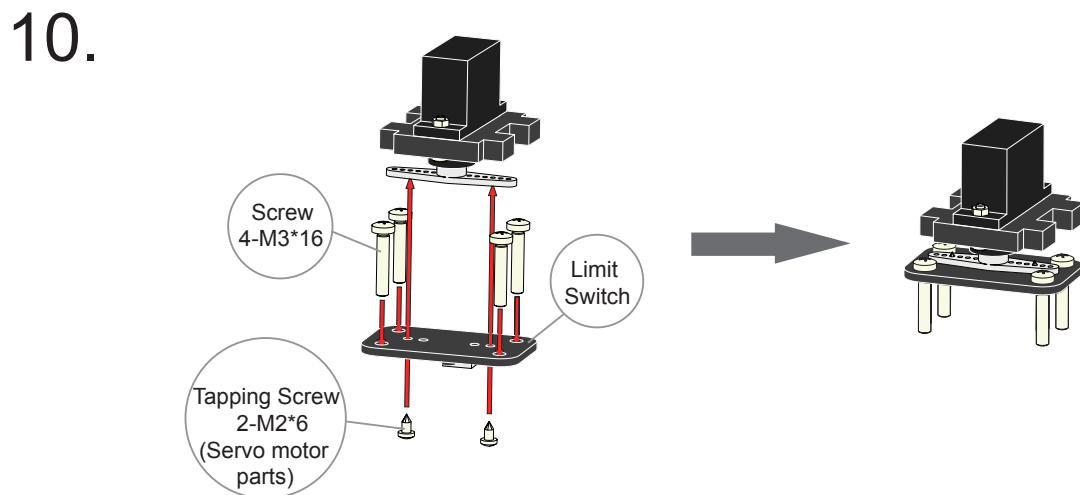
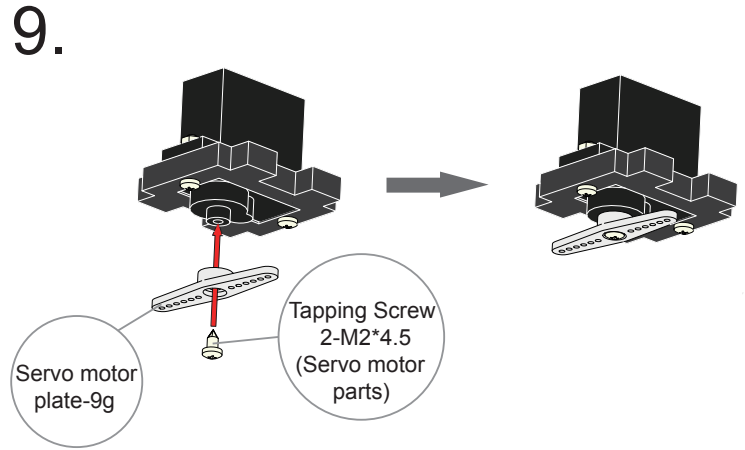
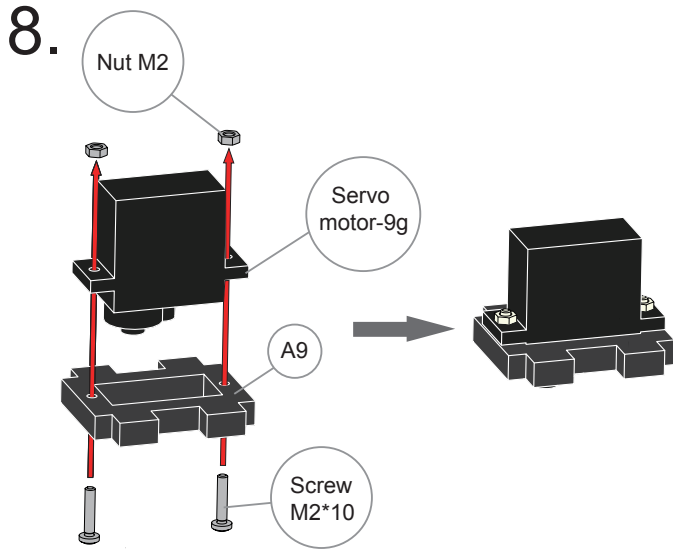
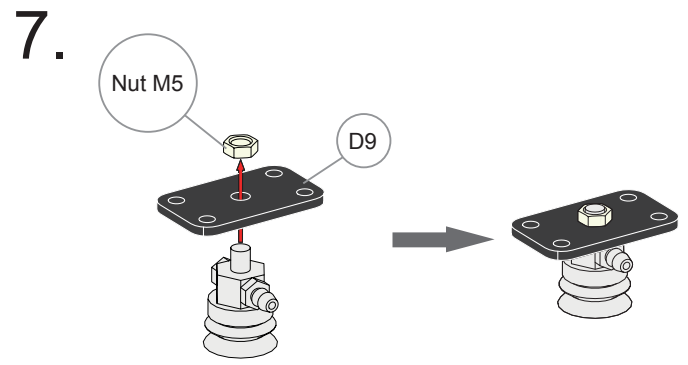
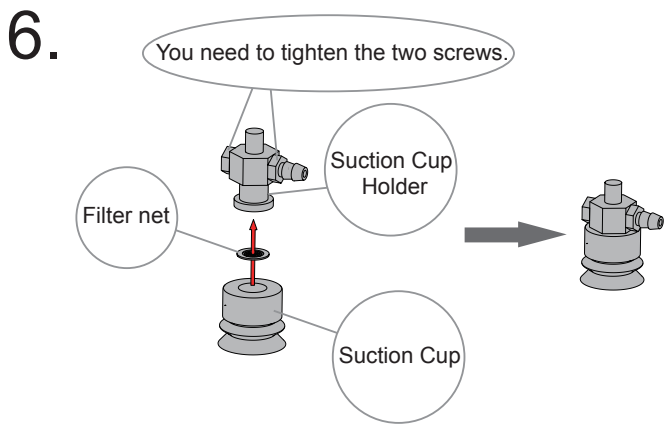

12.

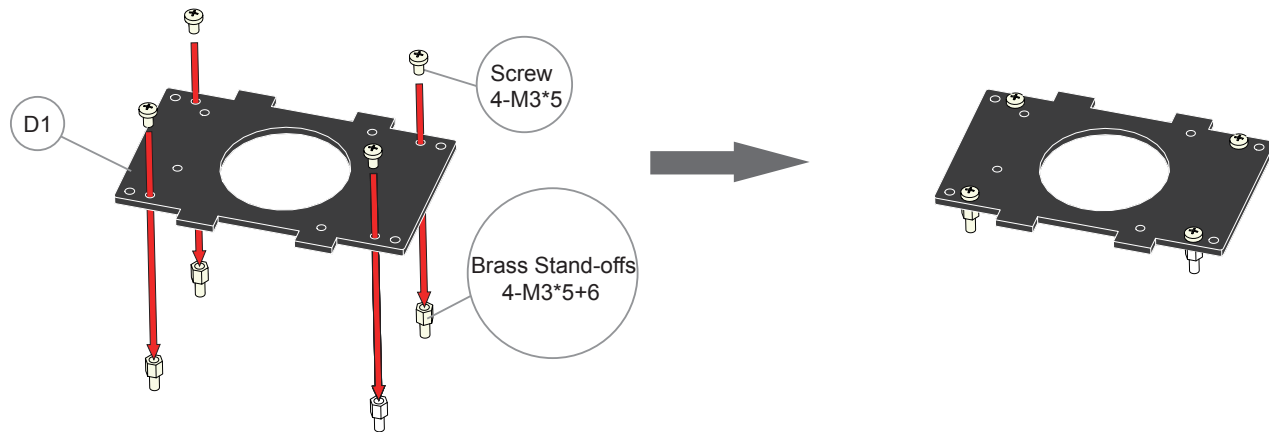

13.

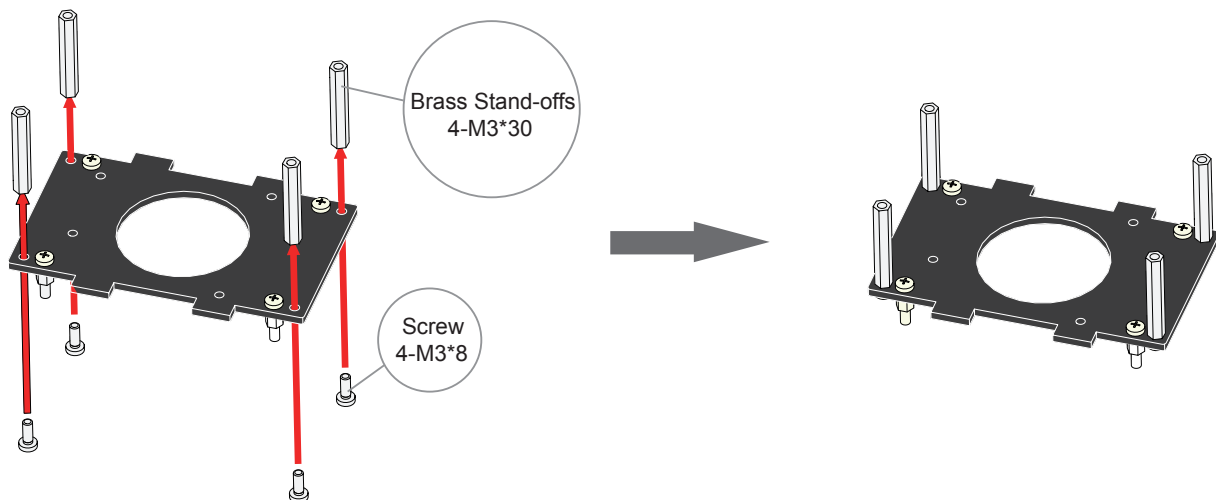

14.

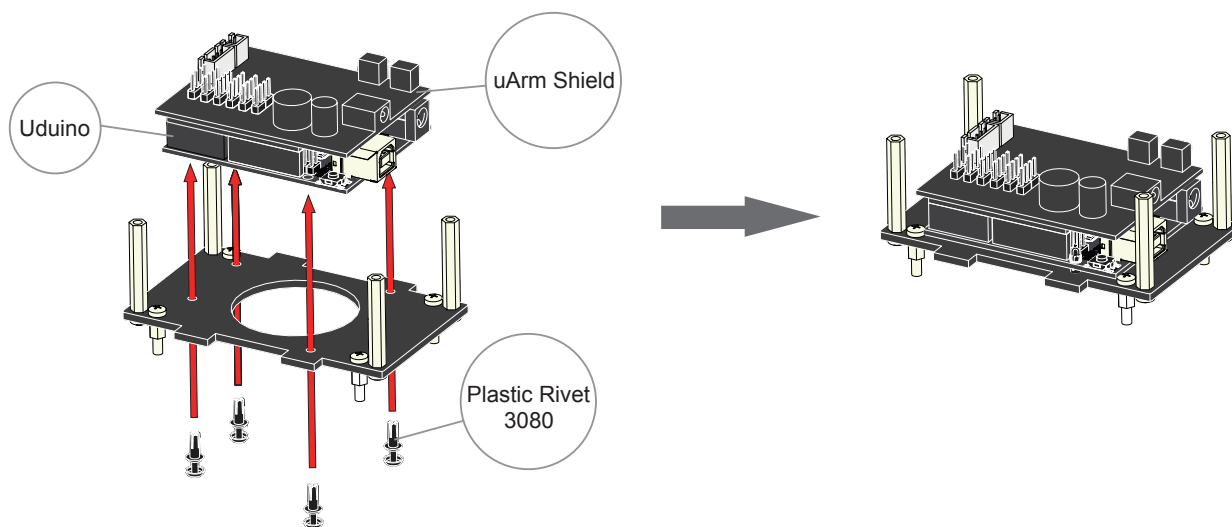

15.

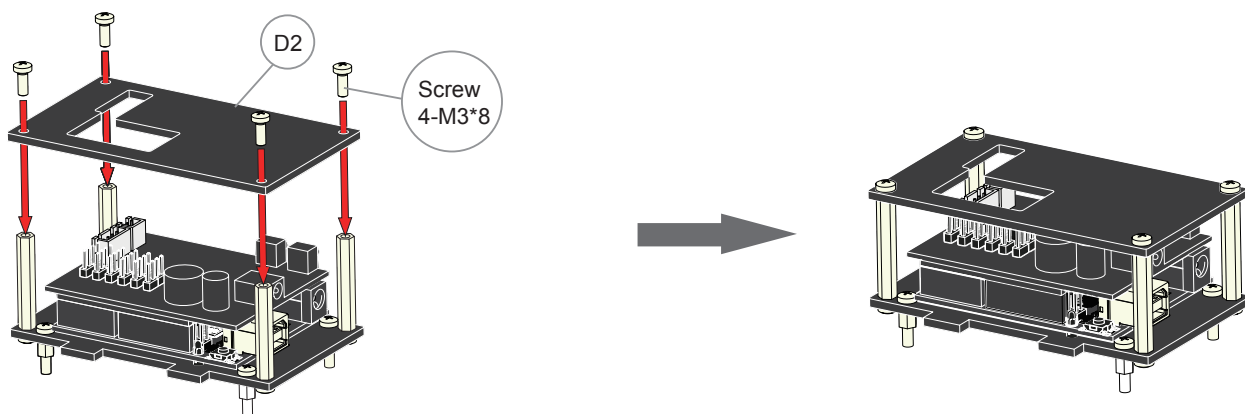

16.

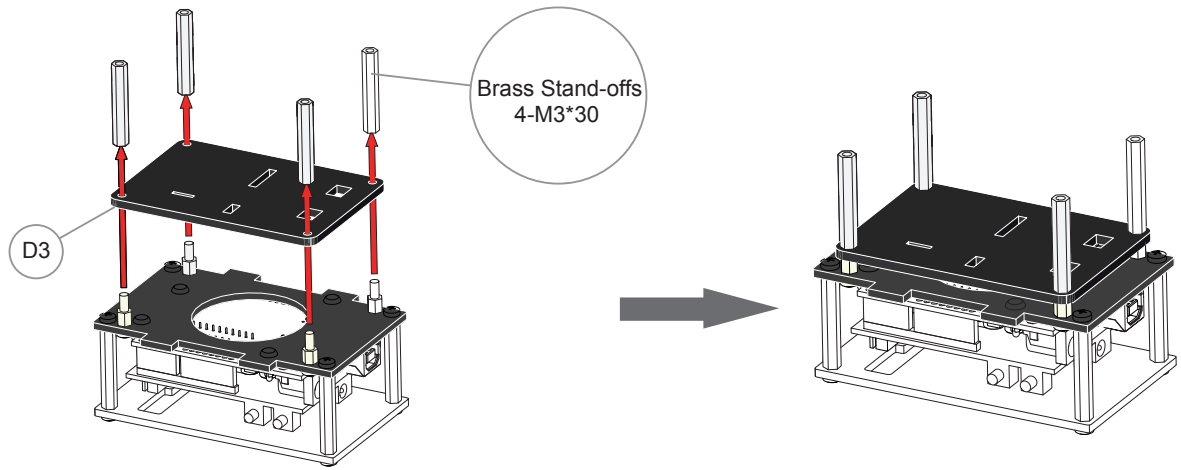

17.

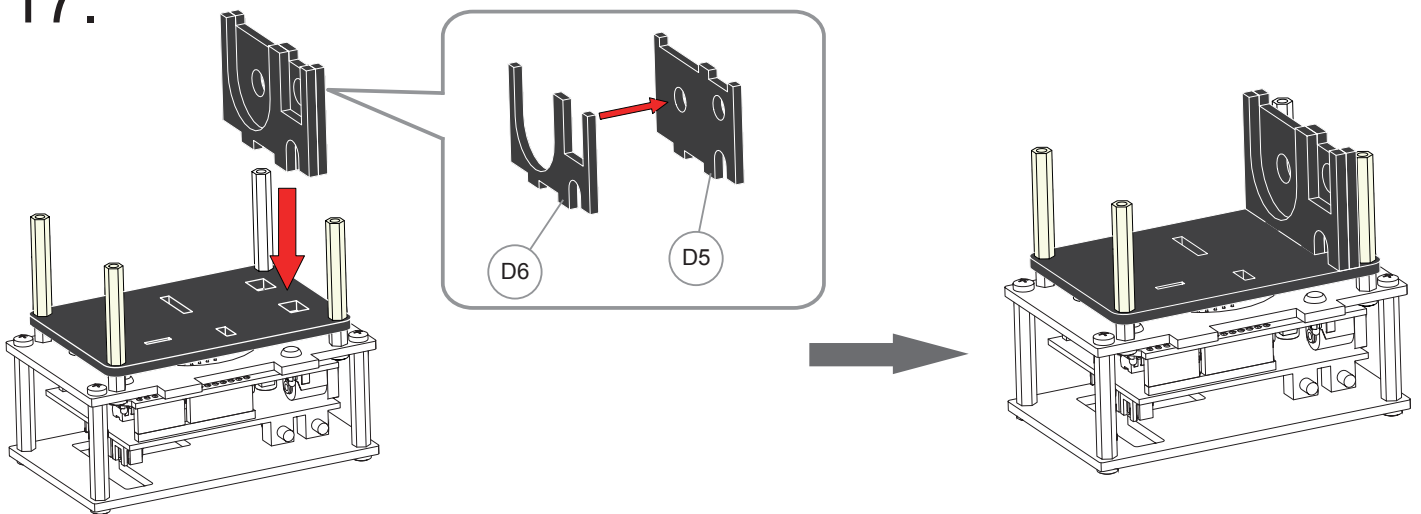

18.

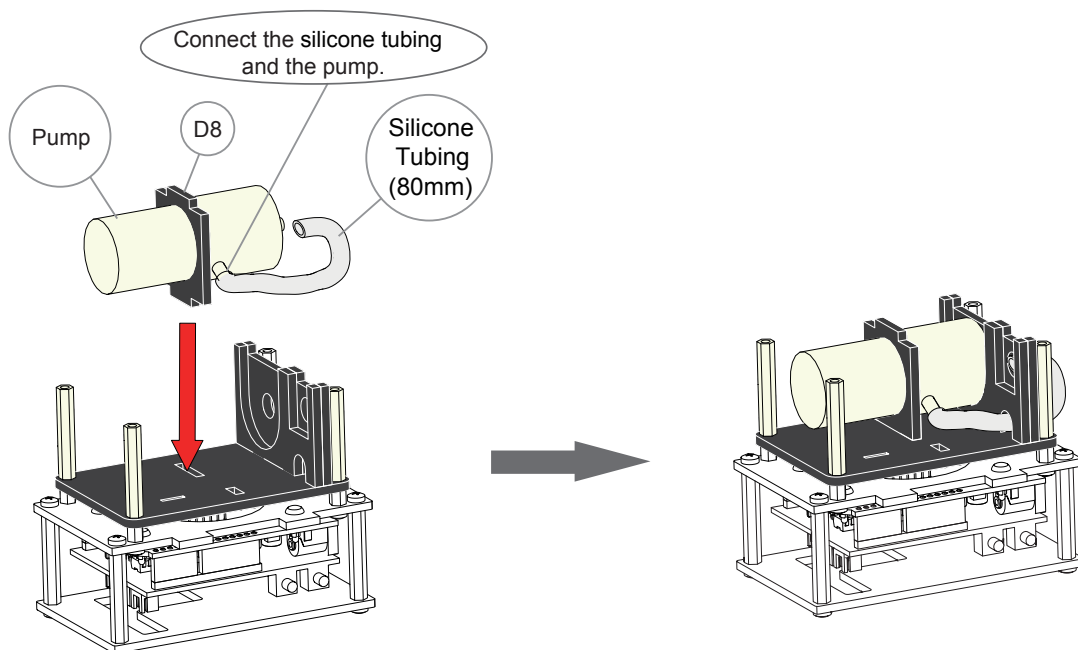

19.

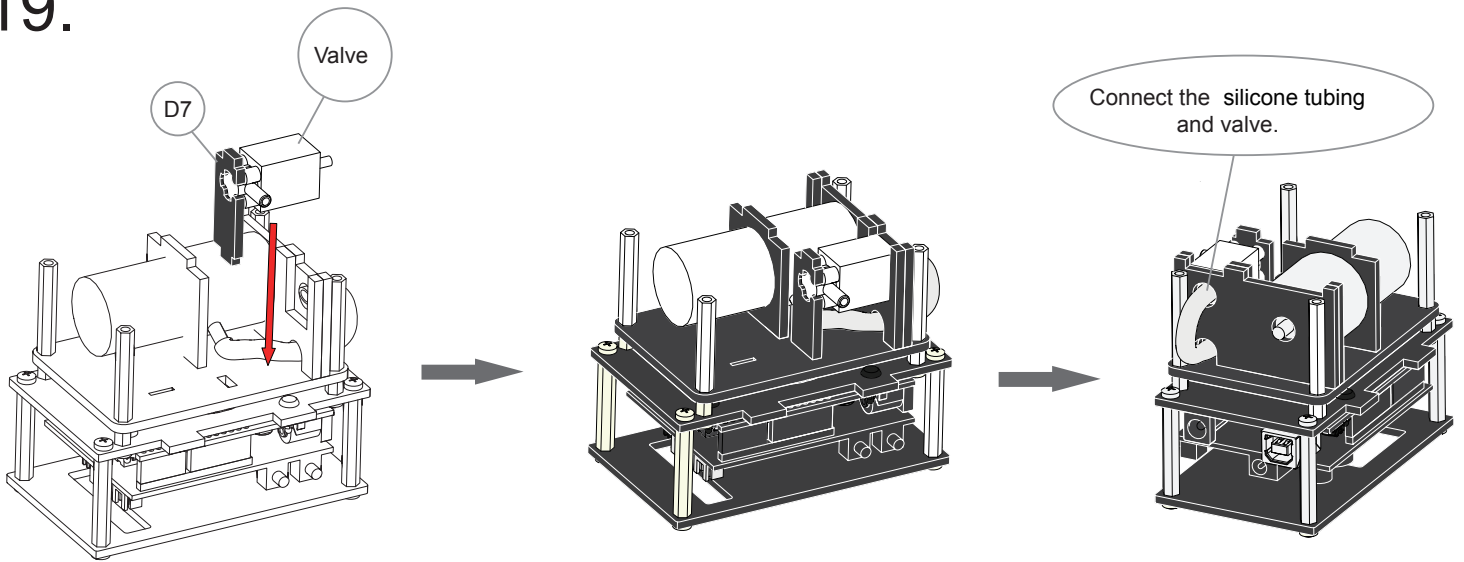

20.

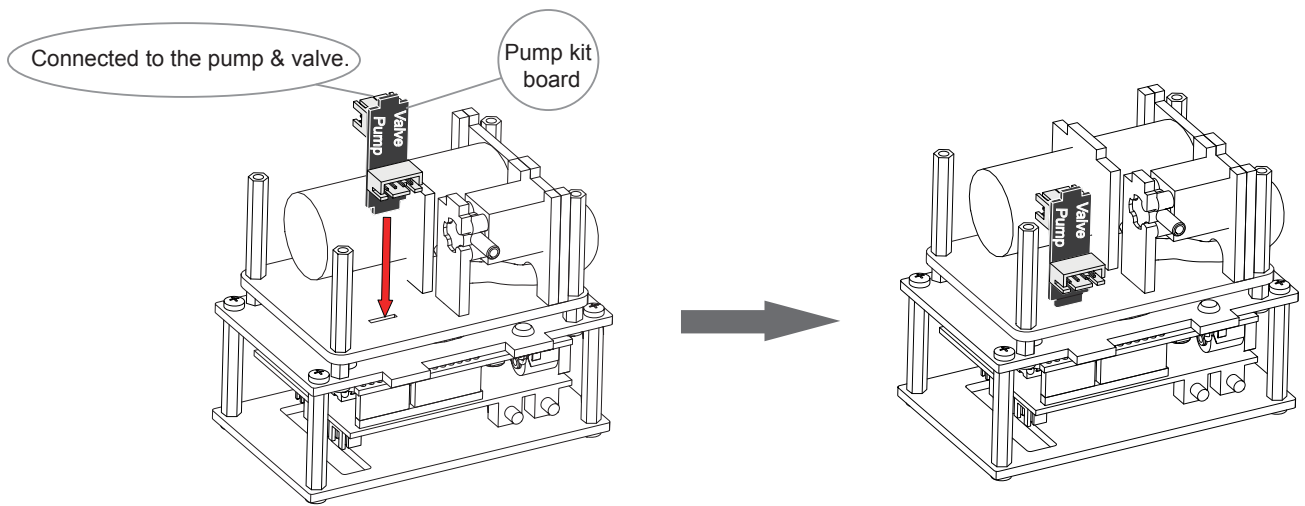

21.

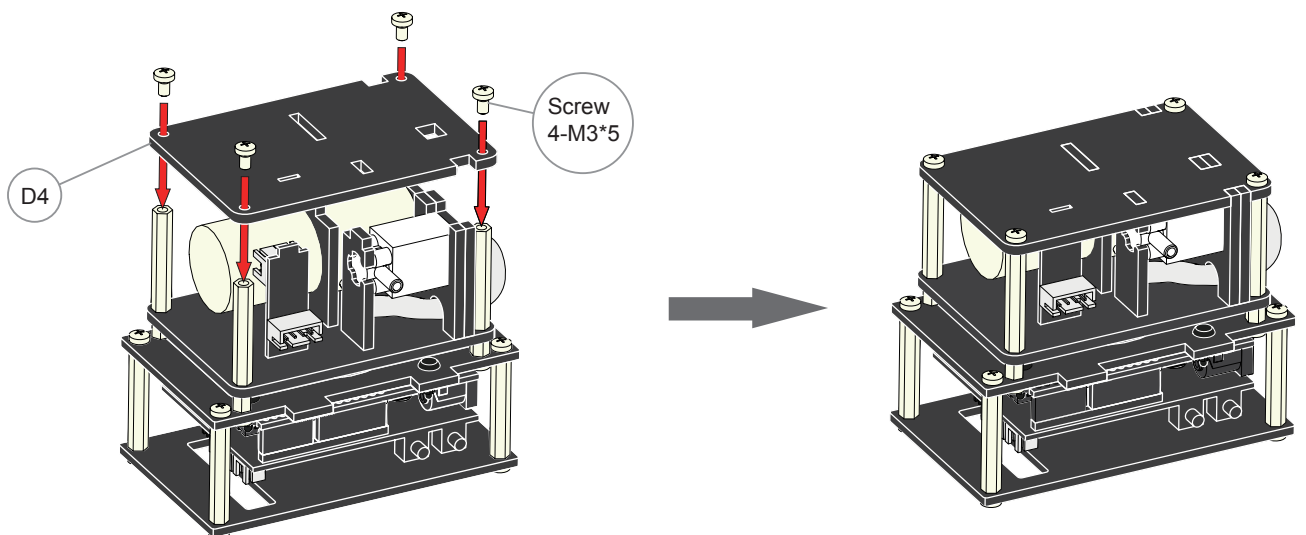

22.

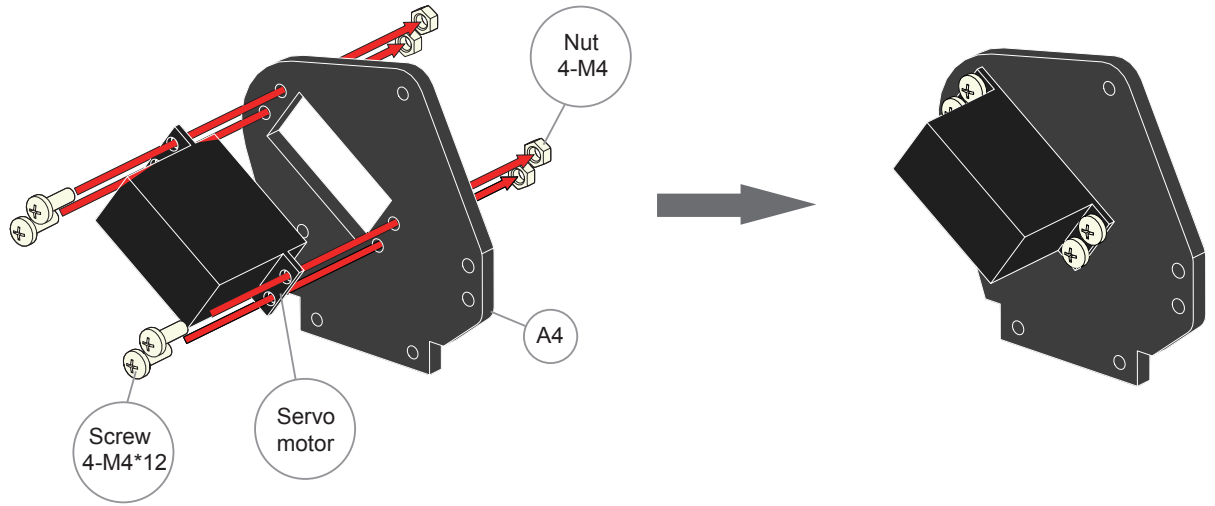

23.

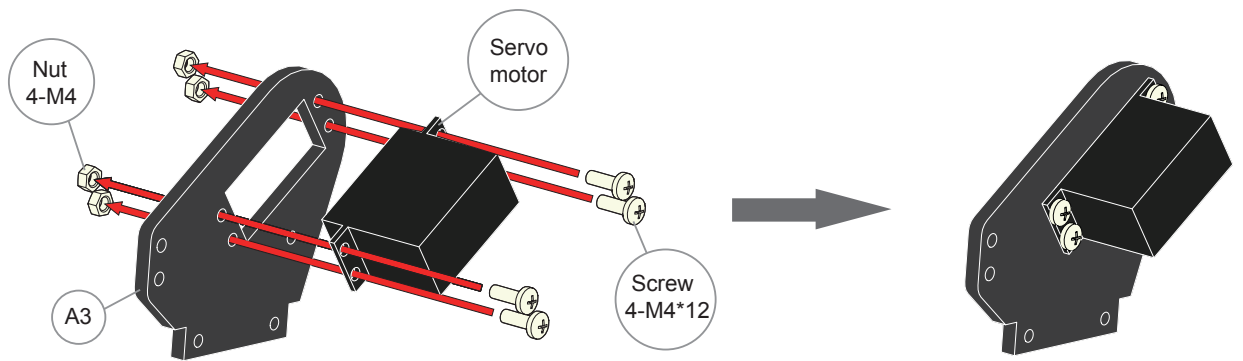

24.

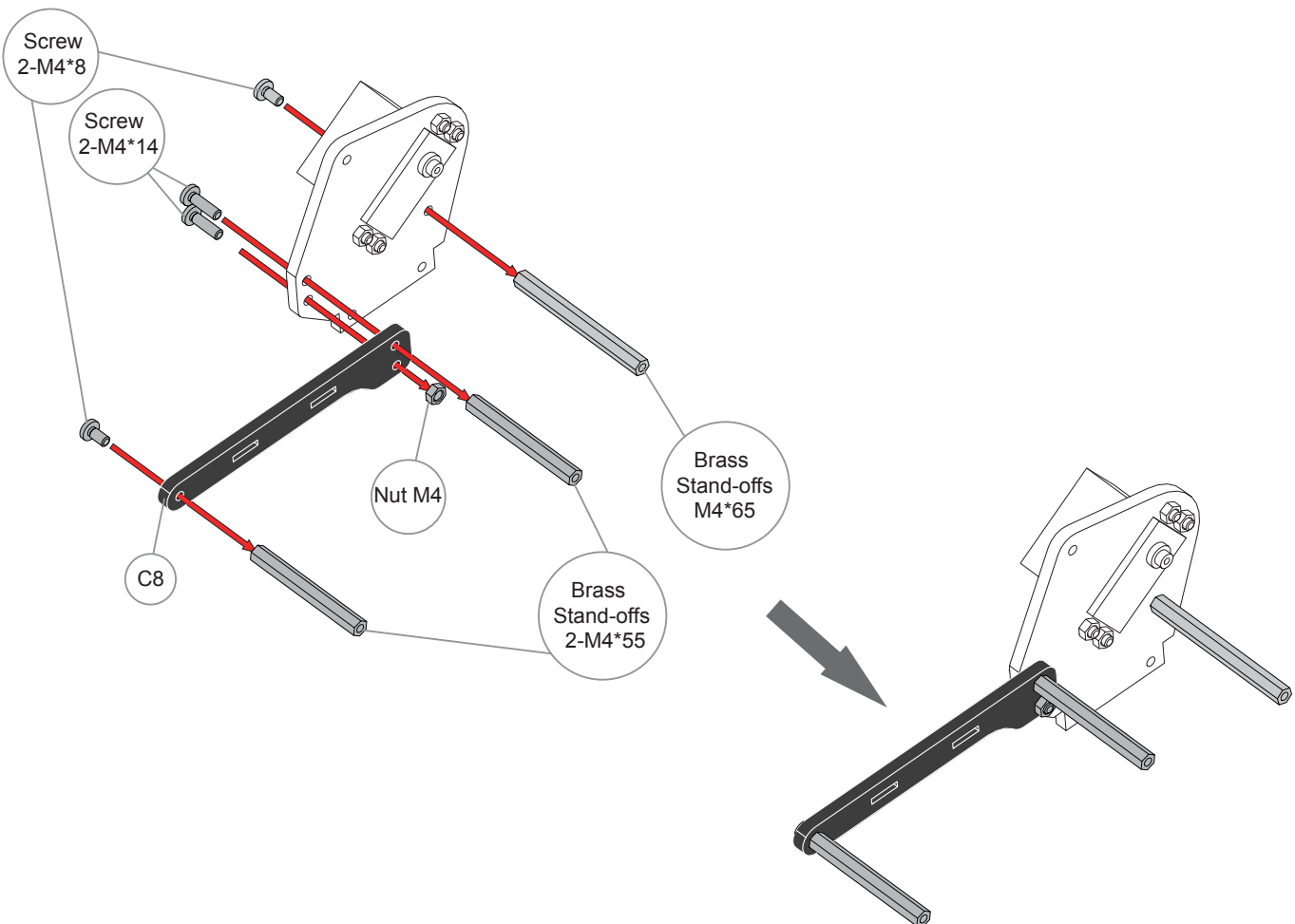

25.

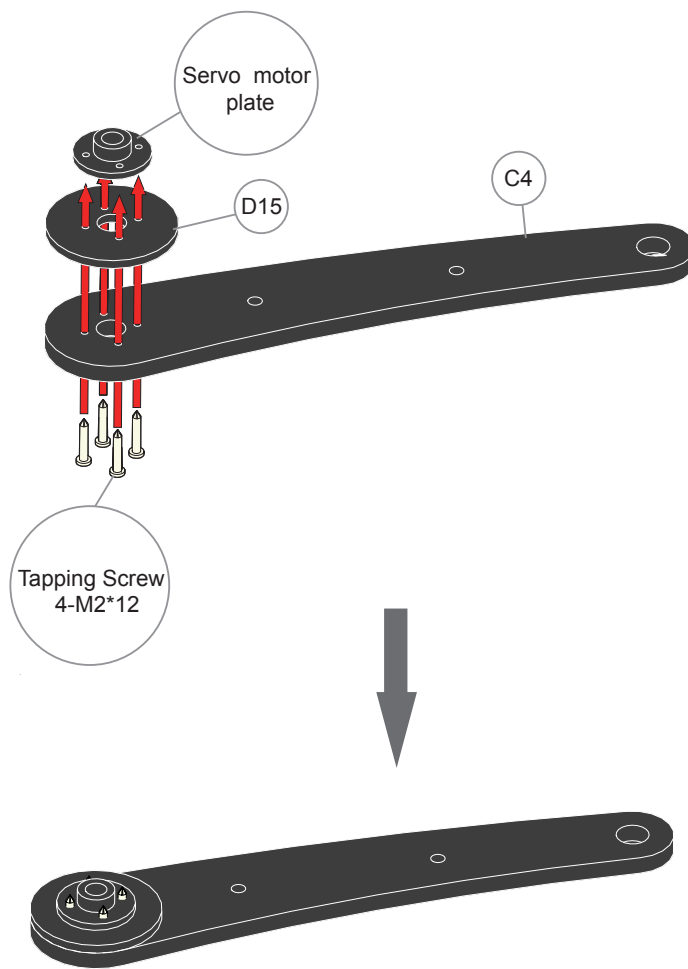

26.

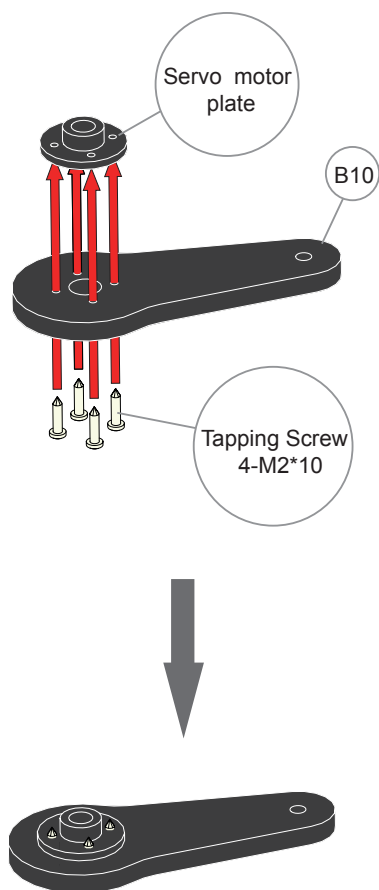

27.

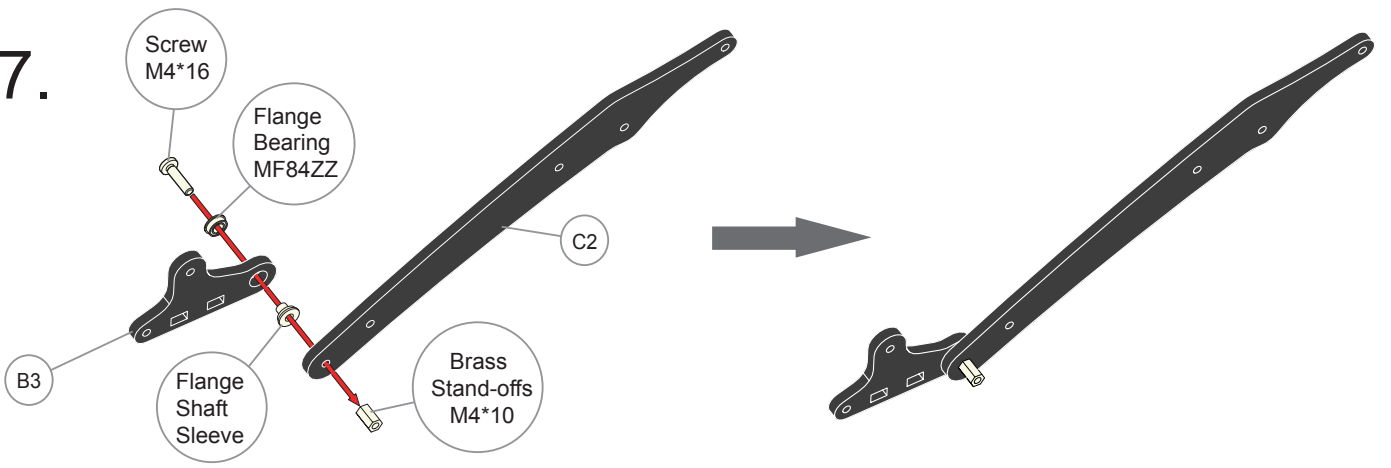

28.

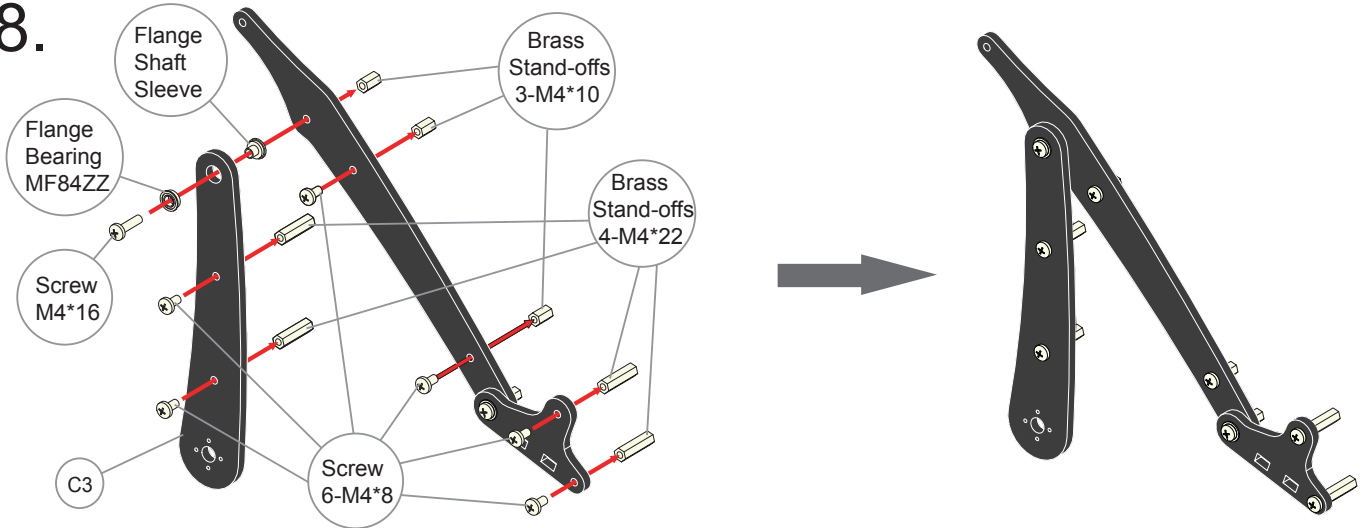

29.

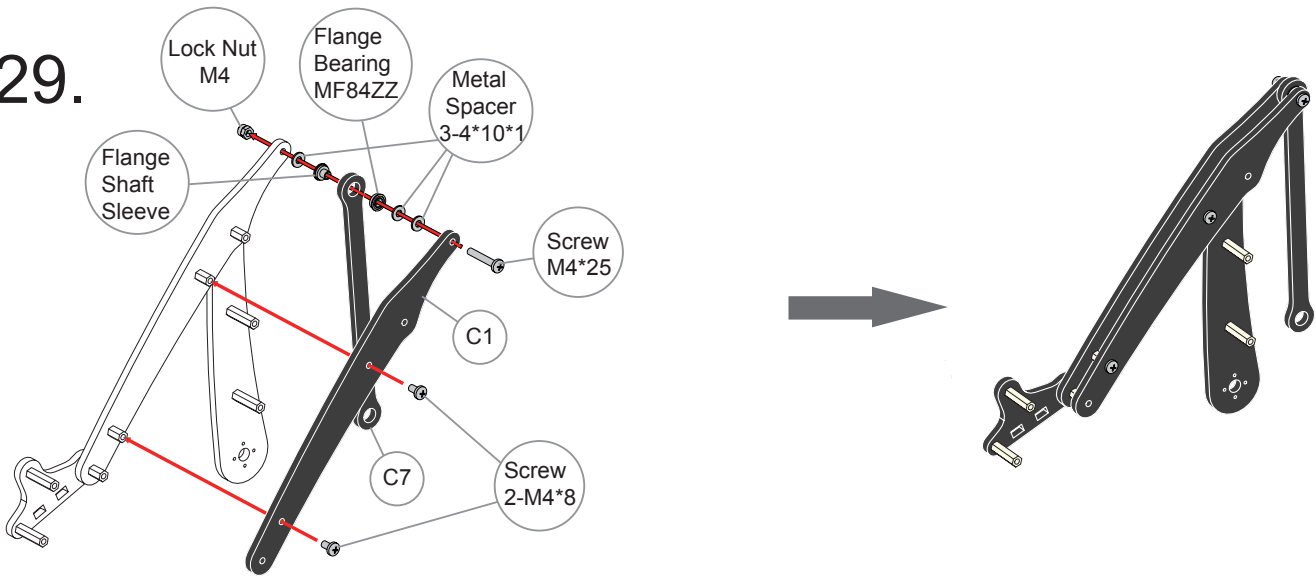

30.

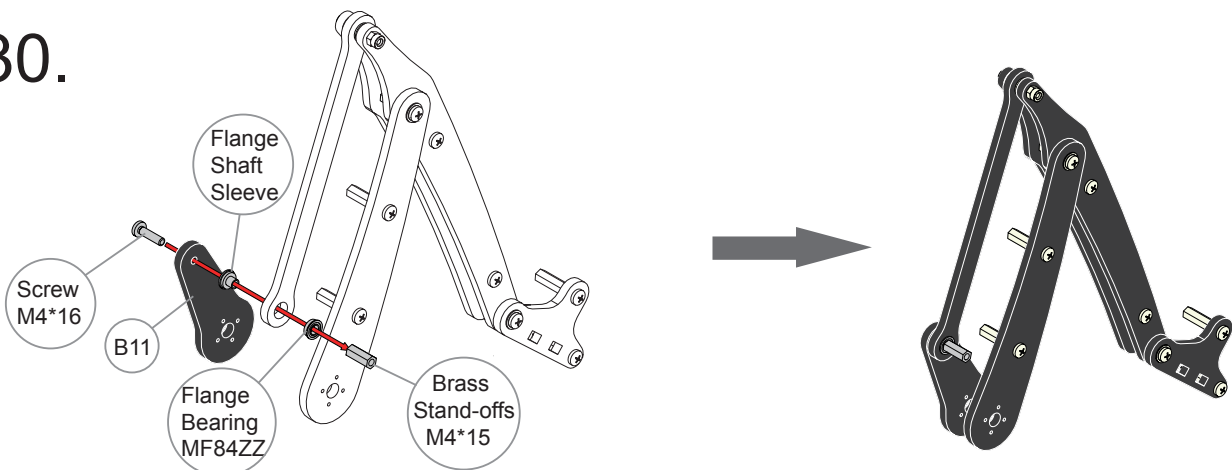

31.

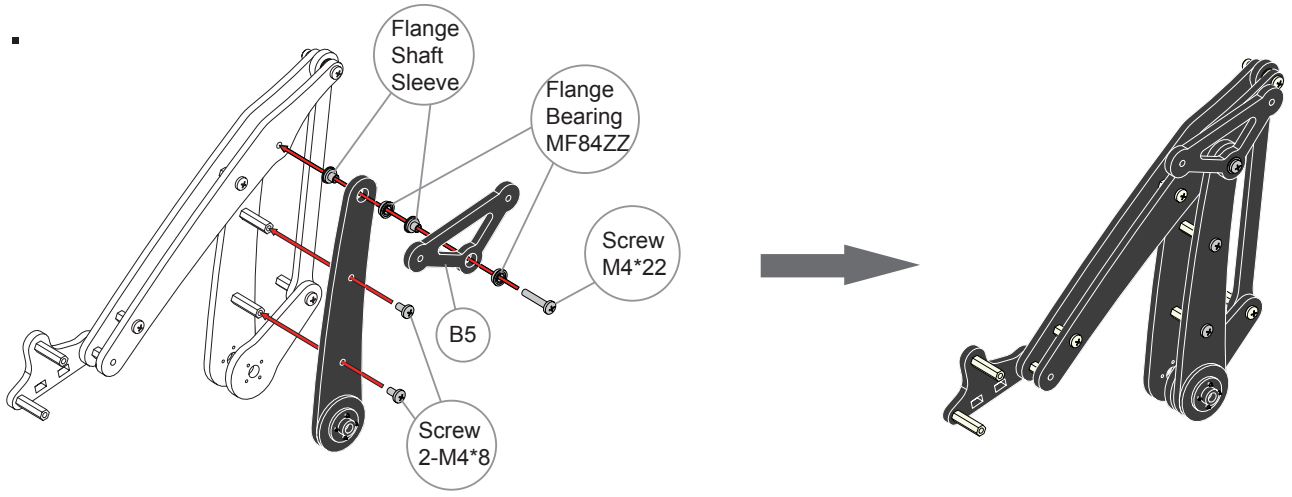

32.

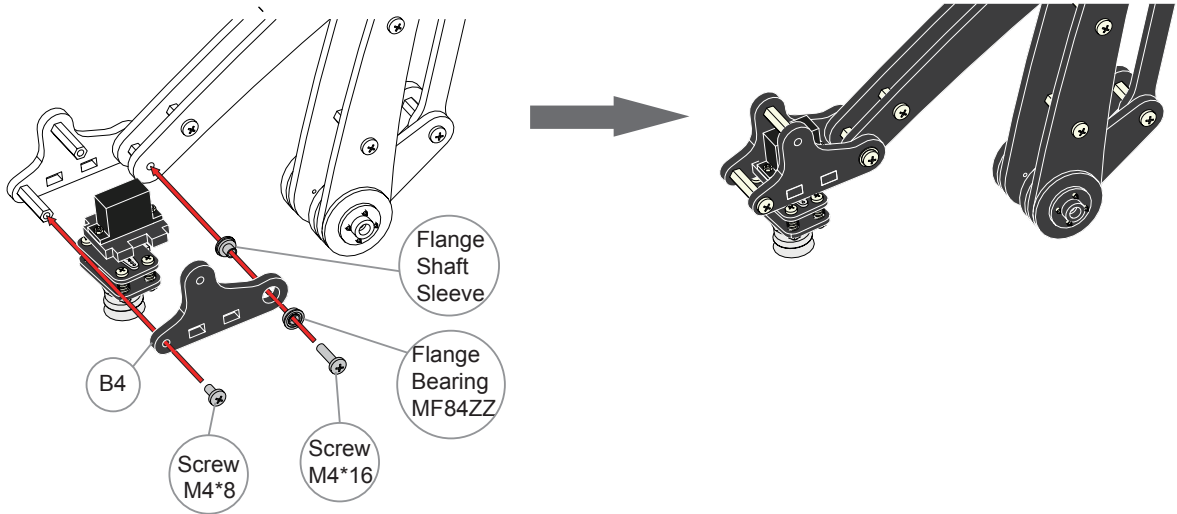

33.

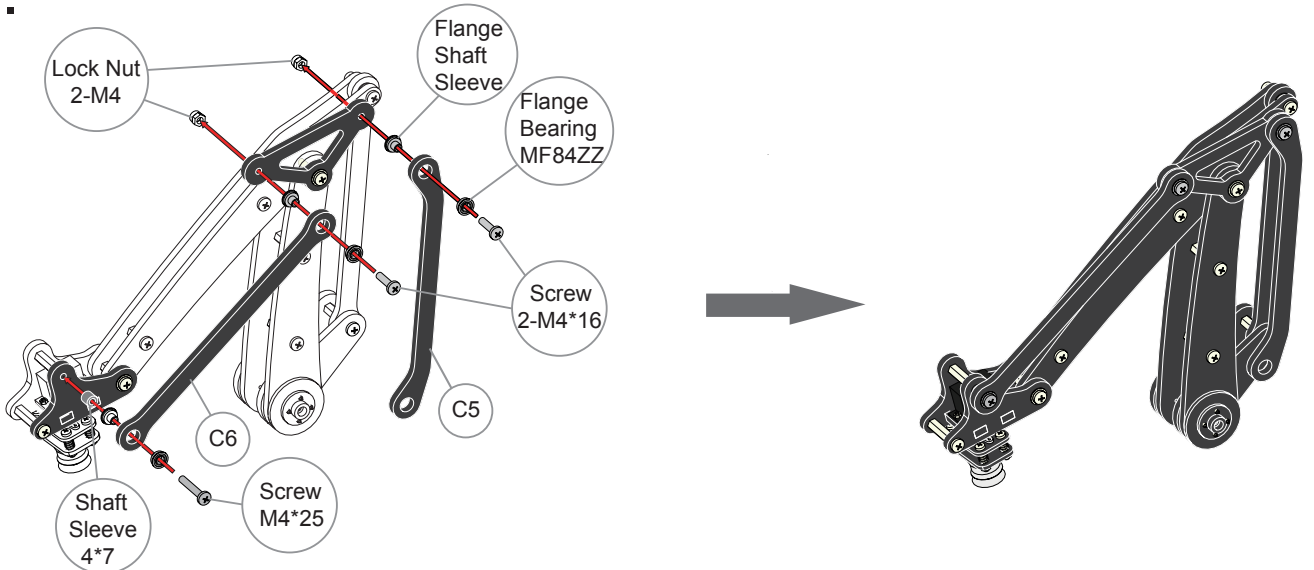

34.

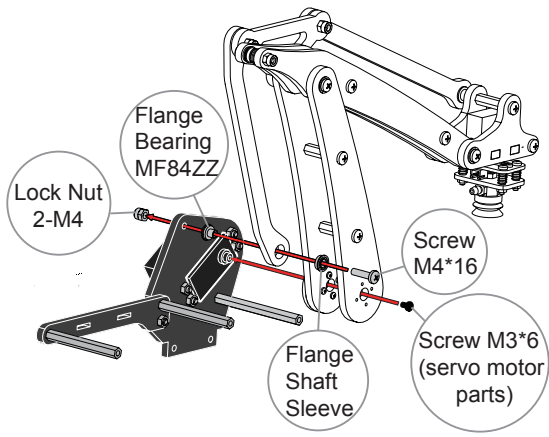

Note that servo motor sports coverage during assembly.

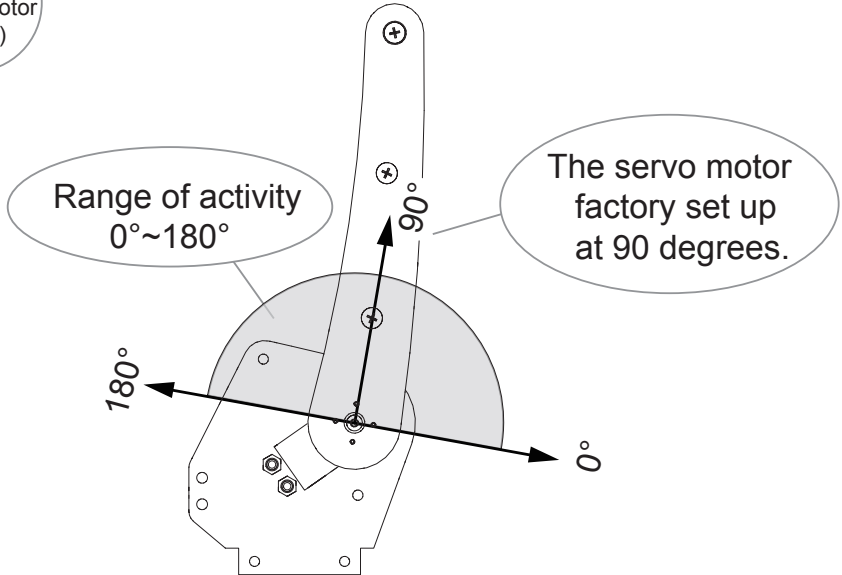
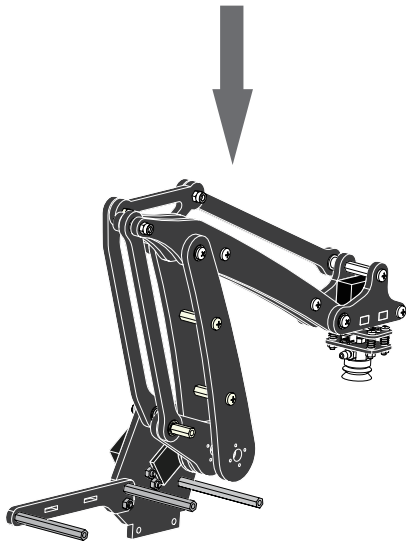

35.

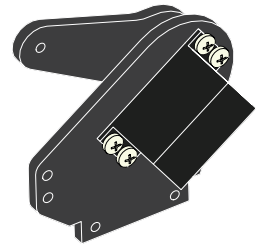
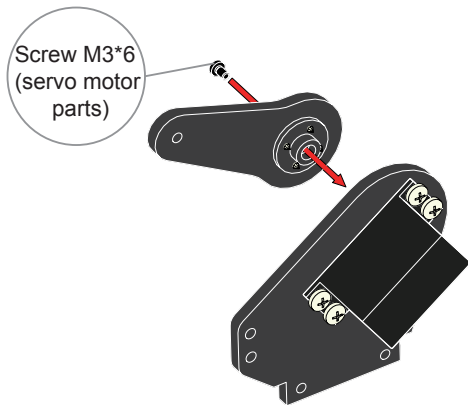

Note that servo motor sports coverage during assembly.

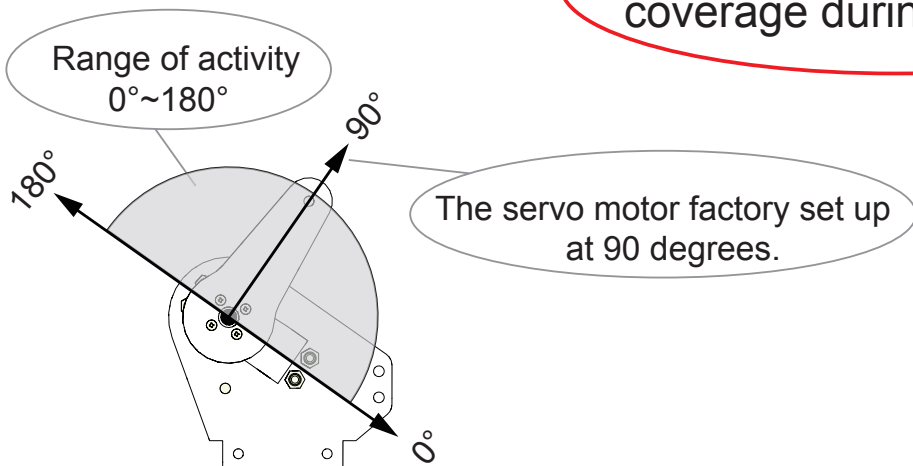

36.

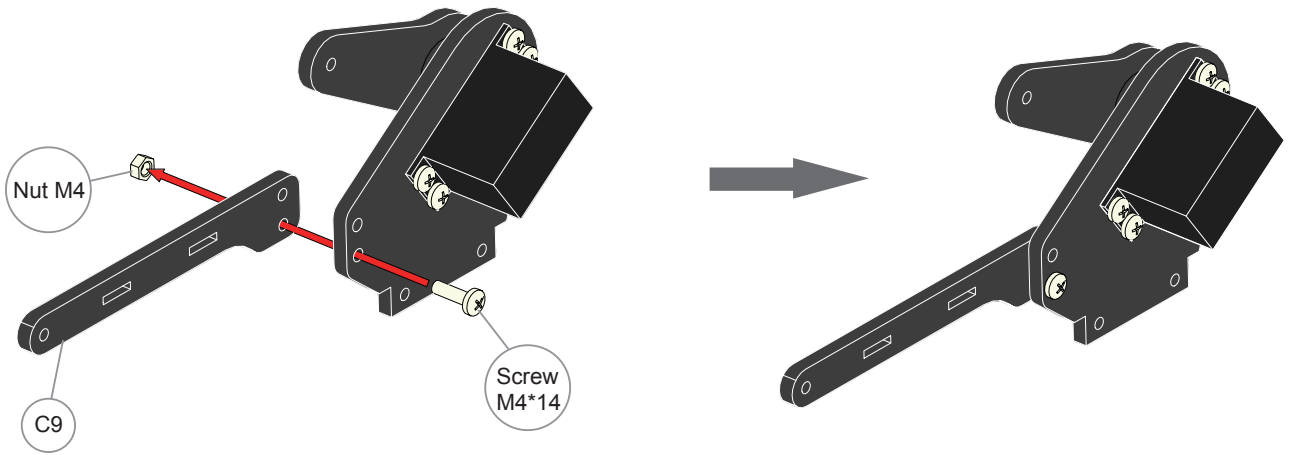

37.

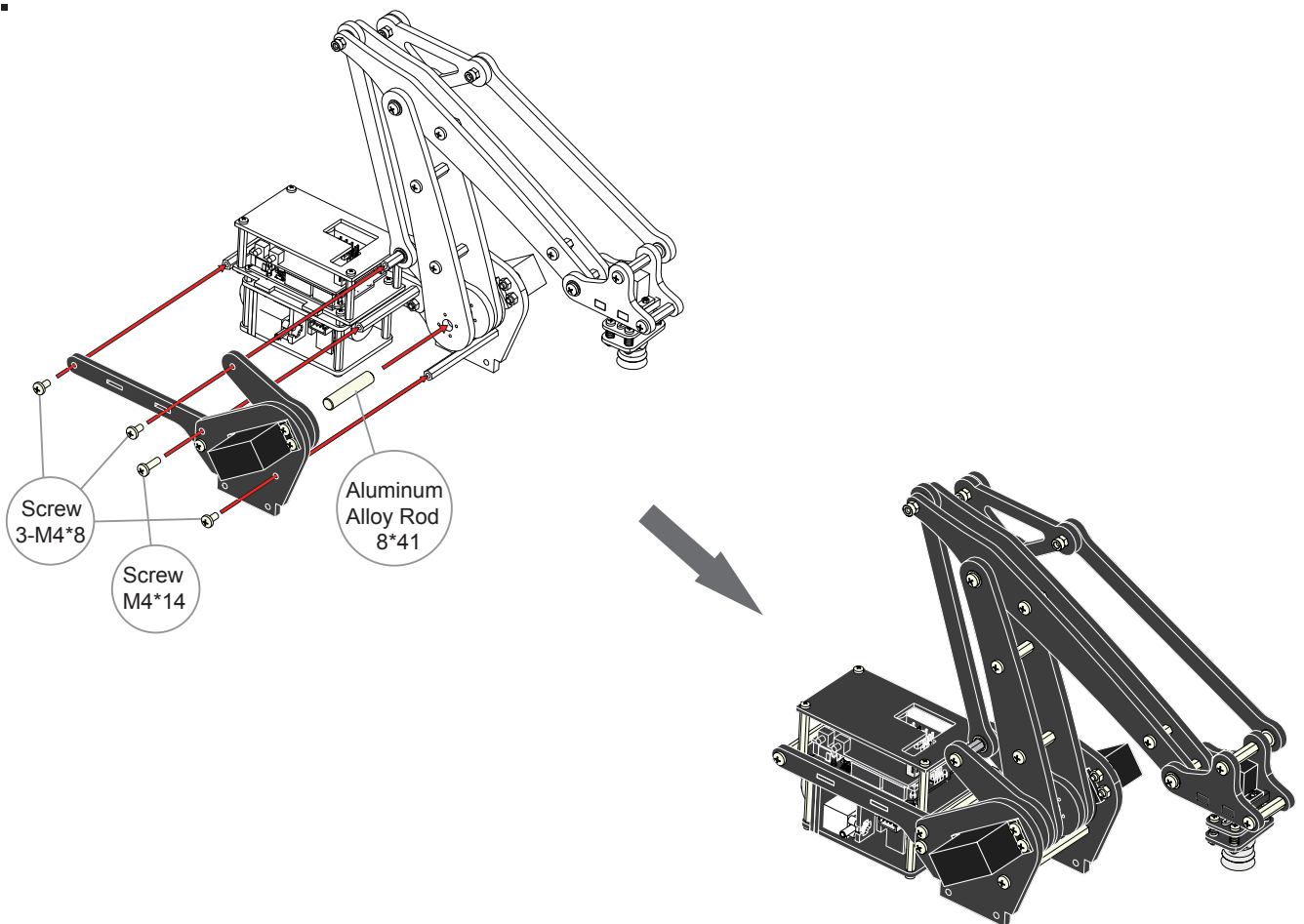

38.

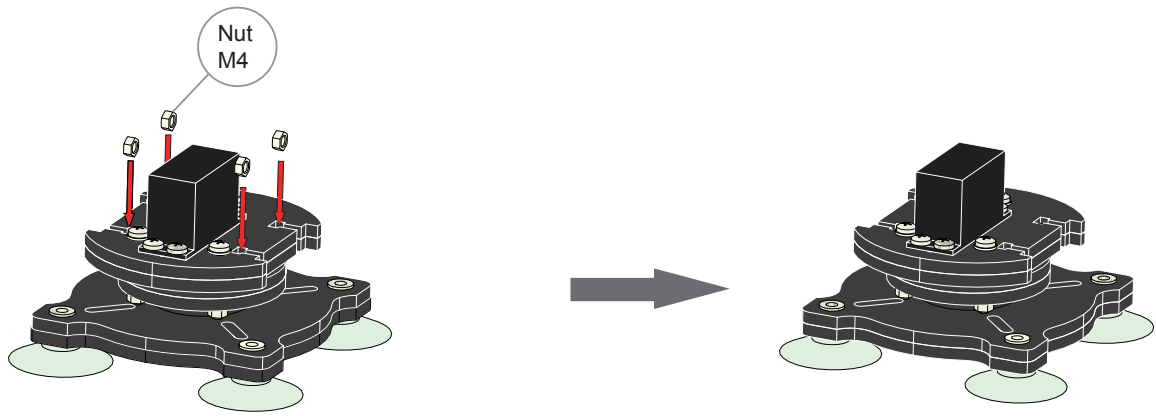

39.

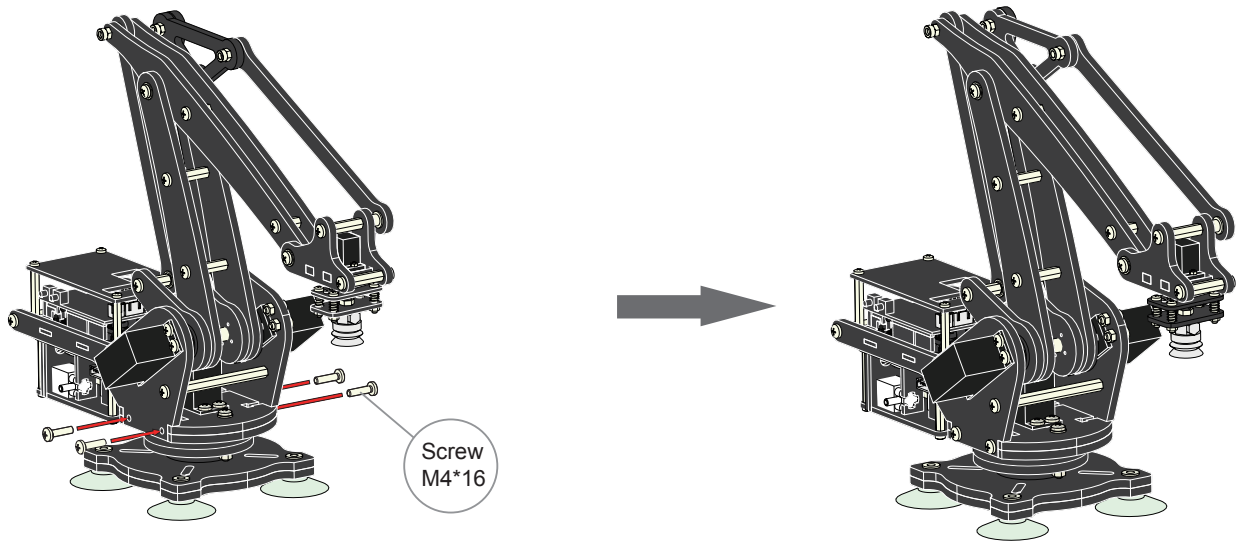

40.

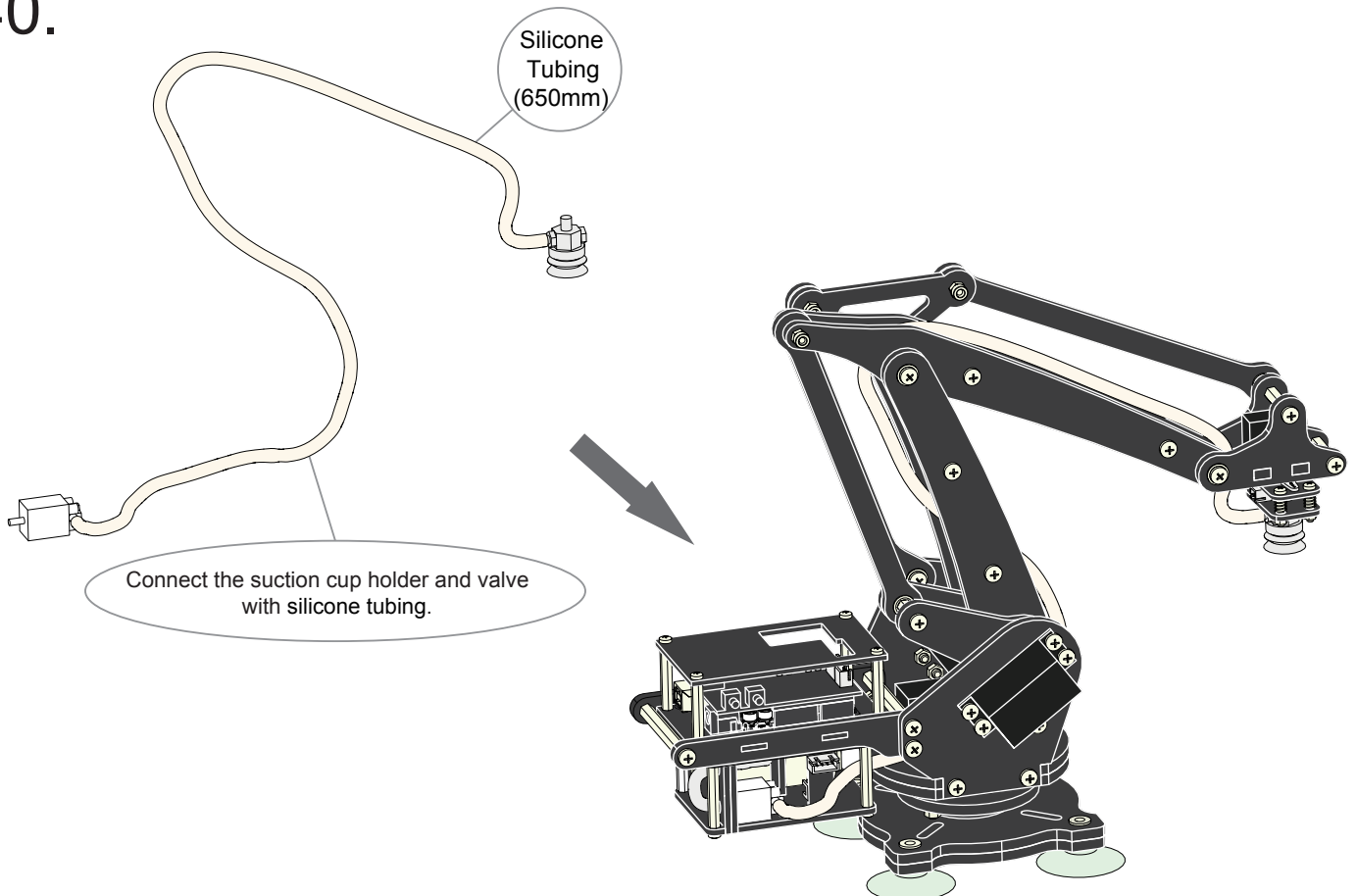

Gripper assembly

1.

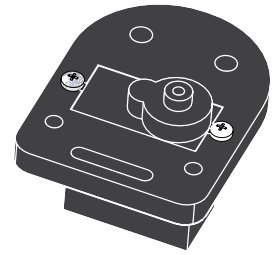
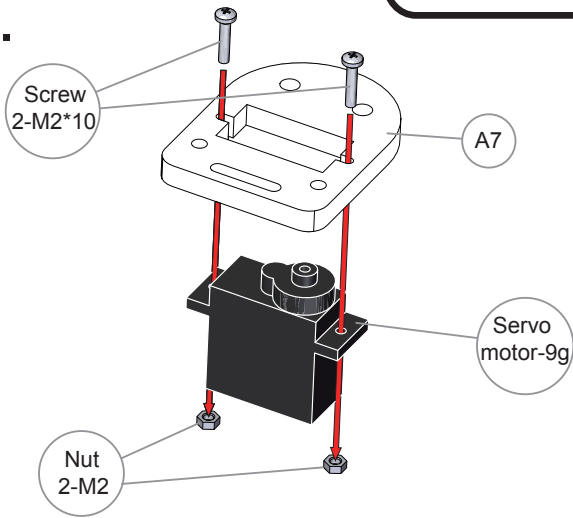

2.

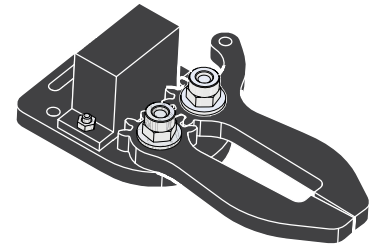
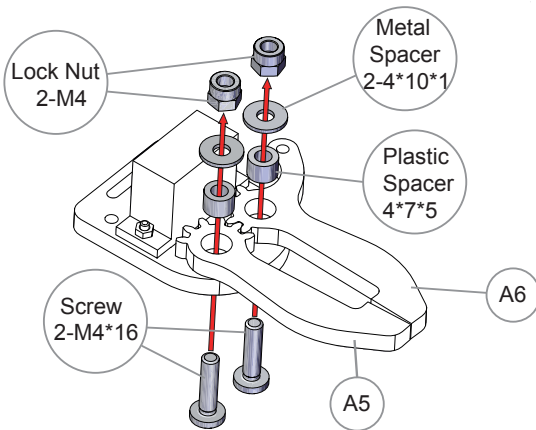

3.

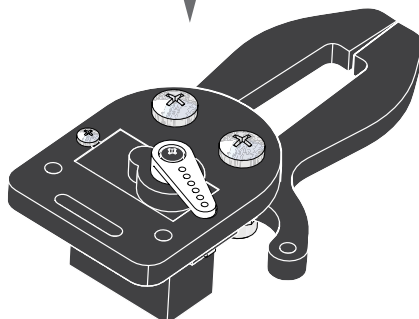
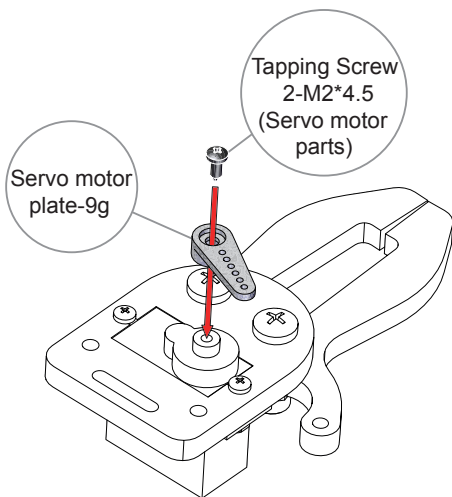

Note that servo motor sports coverage during assembly.

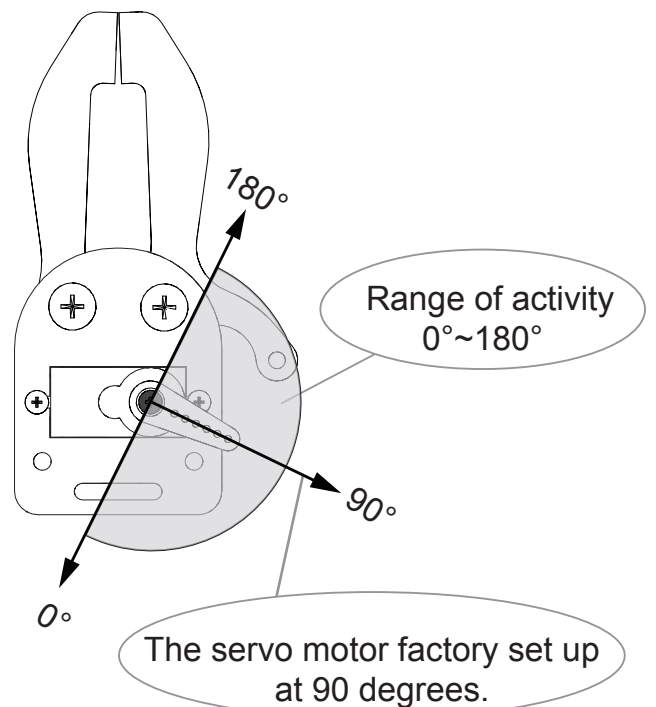

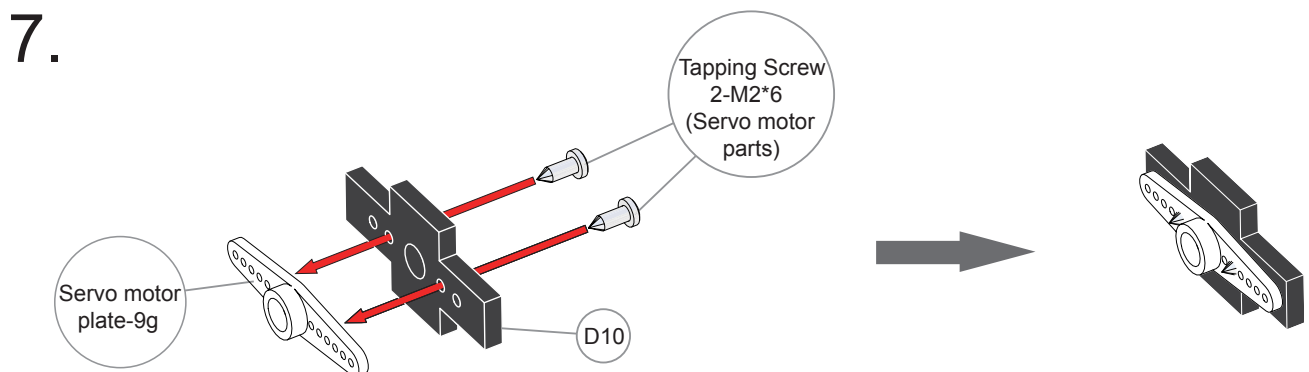
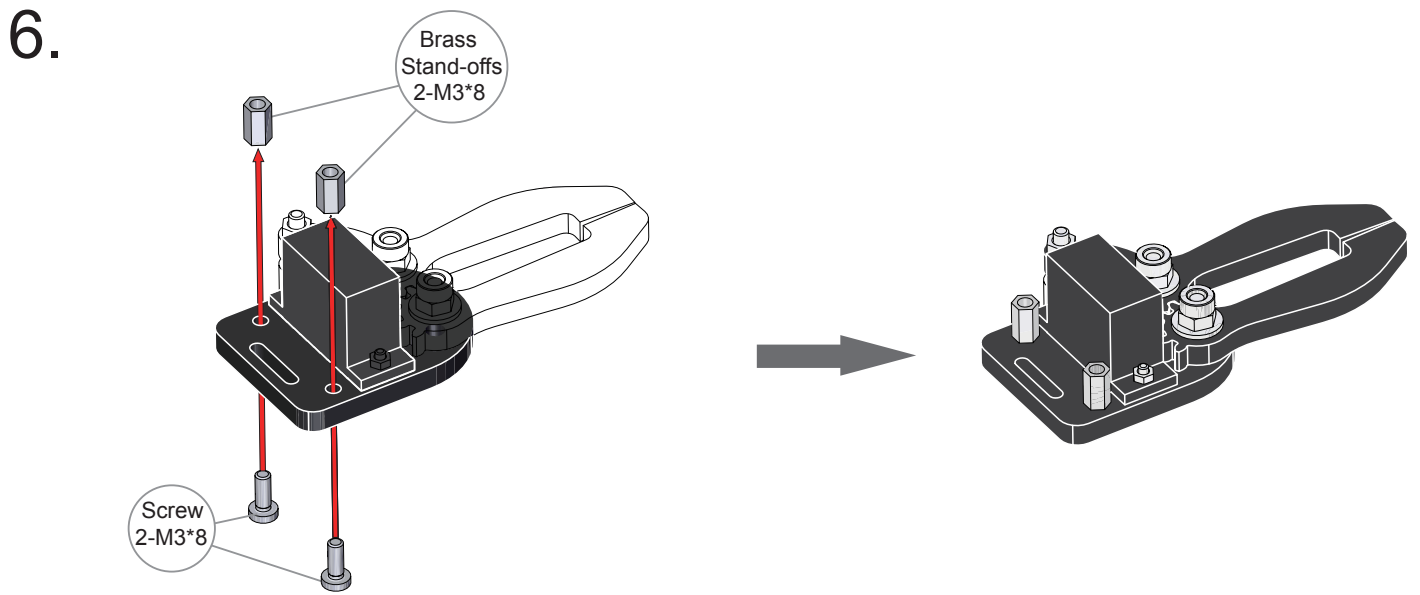
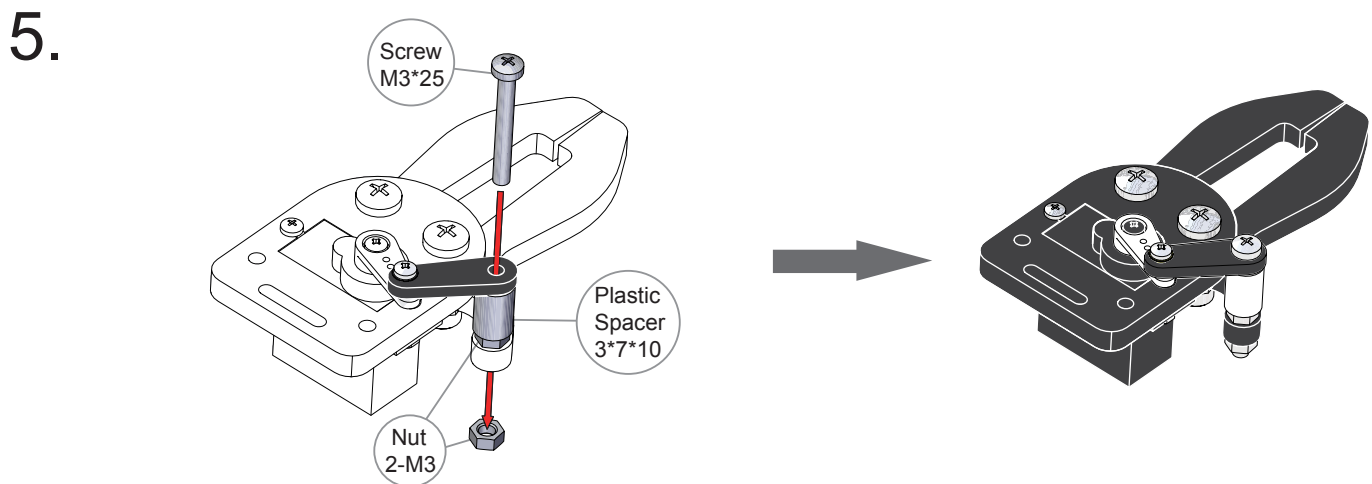
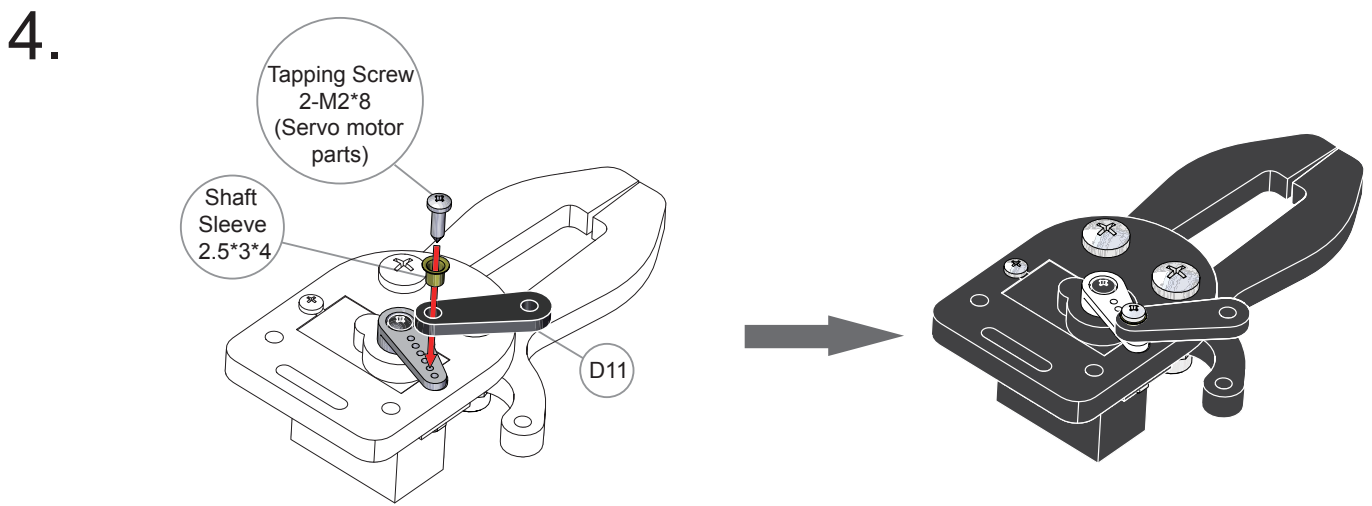

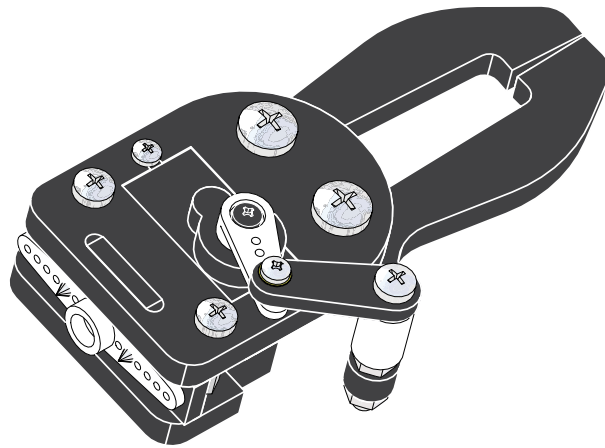
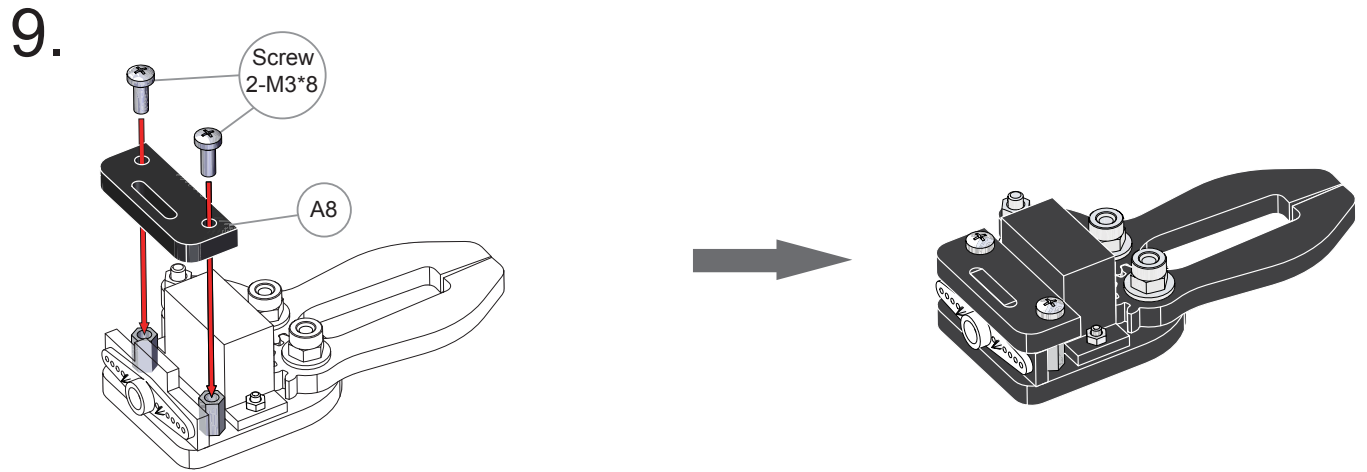
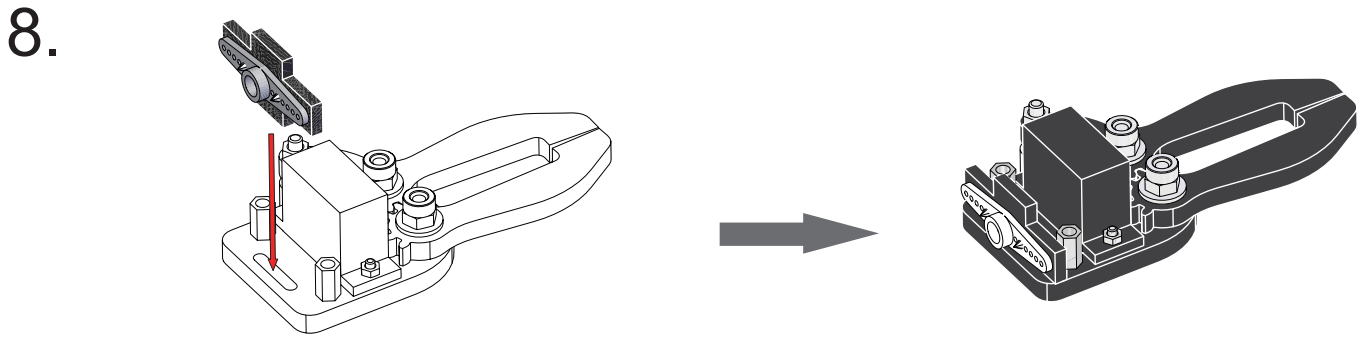

Wiring diagram

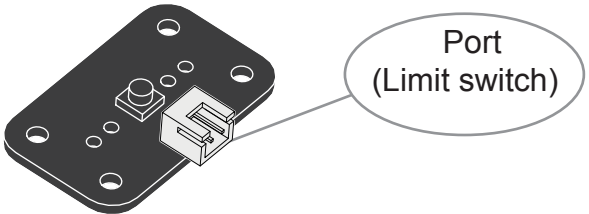
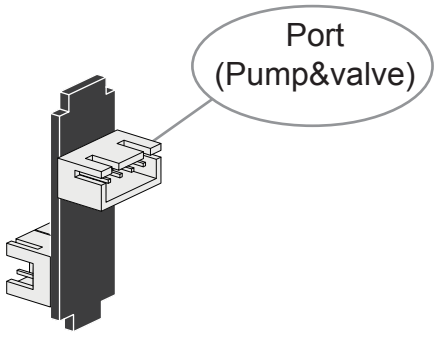

uArm Shield

